

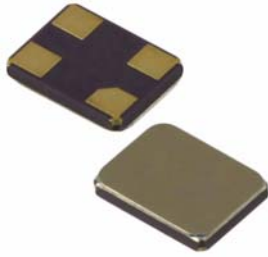

SMD QUARTZ CRYSTAL RESONATOR

石英晶体谐振器



4 Pad Version 3.2x2.5 mm

- ±10 ppm type available
- Excellent Reliability Performance
- EMI shielding possible by grounded lid
- Reflow soldering temperature: 260°C max
- Ceramic Seam Weld package



RoHS compliant

★ PARAMETERS 技术参数

PARAMETERS	参数	SPECIFICATION 规格
Frequency Range	频率范围	12~60MHz
Operation Mode	振动模式	Fundamental
Loading Capacitance	负载电容	9pF Std. 8 to 32pF / Series available
Drive Level	激励电平	10 μ W (200 μ W Max)
Frequency Tolerance	频率偏差	±10ppm~±30ppm (at 25°C)
Equivalent Resistance	谐振电阻	80 Ω Max
Frequency Stability	频率稳定性	±10ppm~±50ppm
Operating Temp. Range:	工作温度范围	-10~+60°C to -40~+85°C
Storage Temp. Range:	储存温度范围	-55~+125°C

○ All specification subject change without notice. 规格变化, 恕不另行通知。

★ FREQUENCY STABILITY VS. TEMPERATURE 频率温度特性

Operation Temperature Range	Frequency Stability				
	±10ppm	±15ppm	±20ppm	±30ppm	±50ppm
-10°C~+60°C	●	○	○	○	○
-20°C~+70°C	○	○	●	○	○
-40°C~+85°C		○	○	●	○

● standard ○ available

★ ESR (SERIES RESISTANCE RS) 谐振电阻

Frequency	Vibration Mode	ESR
12-15.999MHz	AT CUT/FUND.	80Ω(MAX)
16-19.999MHz	AT CUT/FUND.	60Ω(MAX)
20-25.999MHz	AT CUT/FUND.	50Ω(MAX)
26-60.000MHz	AT CUT/FUND.	40Ω(MAX)

★ DIMENSIONS & LAND PATTERN LAYOUT (Unit: mm) 外形尺寸

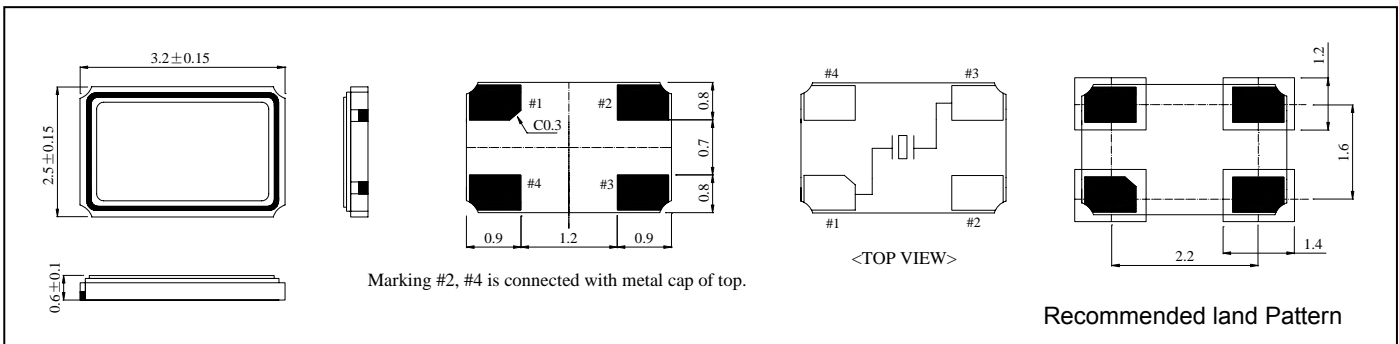

★ PART NUMBER GUIDE 部件号示例 e.g. HLX16.000M10SM3S-10/10B (*SM3S=3.2x2.5 SMD SEAM TYPE)

Logo	Quartz Crystal Resonator 石英晶体谐振器	Frequency 频率 Hz	Load Capacitance 负载电容 pF	Package 盒型	Frequency Tolerance 常温频差 ppm	Frequency Stability 温度频差 ppm	Operating Temp. Range 工作温度
HL	X	16.000M	10	SM3S	10	10	B



Definition	Description
Operating Temperature Range	A: -10~+60℃
	B: -20~+70℃
	C: -30~+80℃
	D: -40~+85℃
	E: Customer specified

★ TAPING SPECIFICATION (Unit: mm) 编带规格

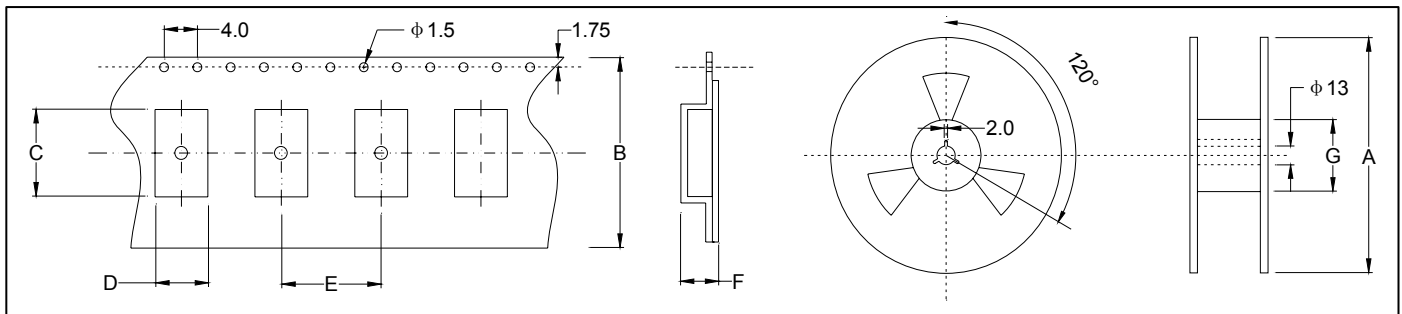

	A	B	C	D	E	F	G
SMD3225	178±2.0	12.0±0.3	3.55±0.10	2.80±0.10	4.0±0.1	0.85±0.10	60.5±1.0
3000 pcs per reel							

★ REFLOW SOLDERING PROFILE 回流焊特性

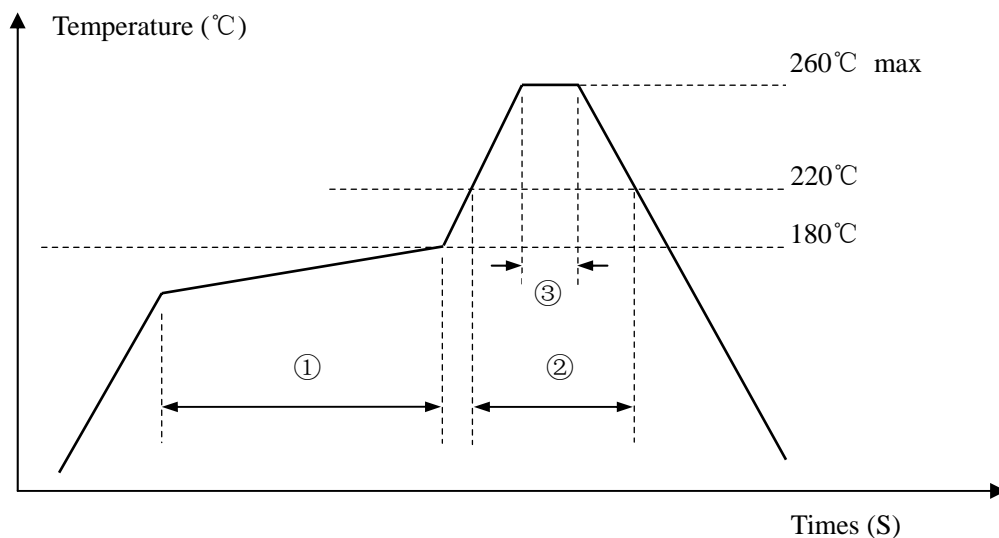

Pb free reflow A	①	Preheat	160~180℃	120sec. max
	②	Primary heat	220℃	60sec. max
	③	Peak	260℃	10sec. max.