

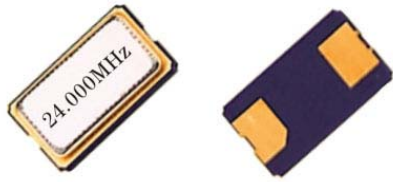

SMD QUARTZ CRYSTAL RESONATOR

石英晶体谐振器



2 Pad Version 6.0x3.5 mm

- ±10 ppm type available
- Excellent Reliability Performance
- EMI shielding possible by grounded lid
- Reflow soldering temperature: 260°C max
- Ceramic Seam Weld package



RoHS compliant

★ PARAMETERS

技术参数

PARAMETERS	参数	SPECIFICATION 规格
Frequency Range	频率范围	7.3~50MHz
Operation Mode	振动模式	Fundamental
Loading Capacitance	负载电容	18pF Std. 8 to 32pF Series available
Drive Level	激励电平	10 μ W (500 μ W Max)
Frequency Tolerance	频率偏差	±10ppm~±30ppm (at 25°C)
Equivalent Resistance	谐振电阻	60 Ω Max
Frequency Stability	频率稳定性	±10ppm~±50ppm
Operating Temp. Range:	工作温度范围	-10~+60°C to -40~+85°C
Storage Temp. Range:	储存温度范围	-55~+125°C

○ All specification subject change without notice. 规格变化, 恕不另行通知。

★ FREQUENCY STABILITY VS. TEMPERATURE 频率温度特性

★ ESR (SERIES RESISTANCE RS)

Operation Temperature Range	Frequency Stability				
	±10ppm	±15ppm	±20ppm	±30ppm	±50ppm
-10°C~+60°C	●	○	○	○	○
-20°C~+70°C	○	○	●	○	○
-40°C~+85°C		○	○	●	○

Frequency	Vibration Mode	ESR
7.3-11.999MHz	AT CUT/FUND.	60Ω(MAX)
12-15.999MHz	AT CUT/FUND.	50Ω(MAX)
16-24.999MHz	AT CUT/FUND.	40Ω(MAX)
25-50.000MHz	AT CUT/FUND.	30Ω(MAX)

● standard ○ available

★ DIMENSIONS & LAND PATTERN LAYOUT (Unit: mm) 外形尺寸

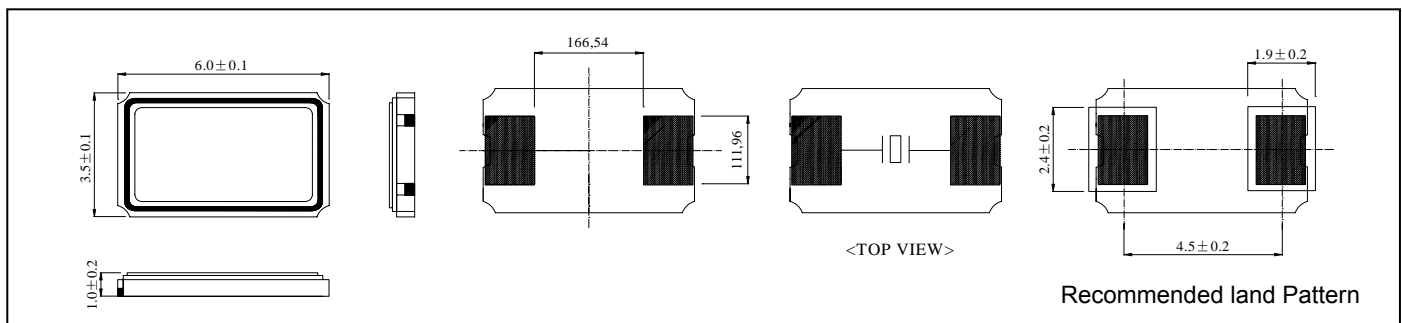

★ PART NUMBER GUIDE 部件号示例 e.g. HLX12.000M18SM6A-20/20B (*SM6A=6.0x3.5 SMD SEAM 2PAD TYPE)

Logo	Quartz Crystal Resonator 石英晶体谐振器	Frequency 频率 Hz	Load Capacitance 负载电容 pF	Package 盒型	Frequency Tolerance 常温频差 ppm	Frequency Stability 温度频差 ppm	Operating Temp. Range 工作温度
HL	X	12.000M	18	SM6A	20	20	B



Definition	Description
Operating Temperature Range	A: -10~+60℃
	B: -20~+70℃
	C: -30~+80℃
	D: -40~+85℃
	E: Customer specified

★ TAPING SPECIFICATION (Unit: mm) 编带规格

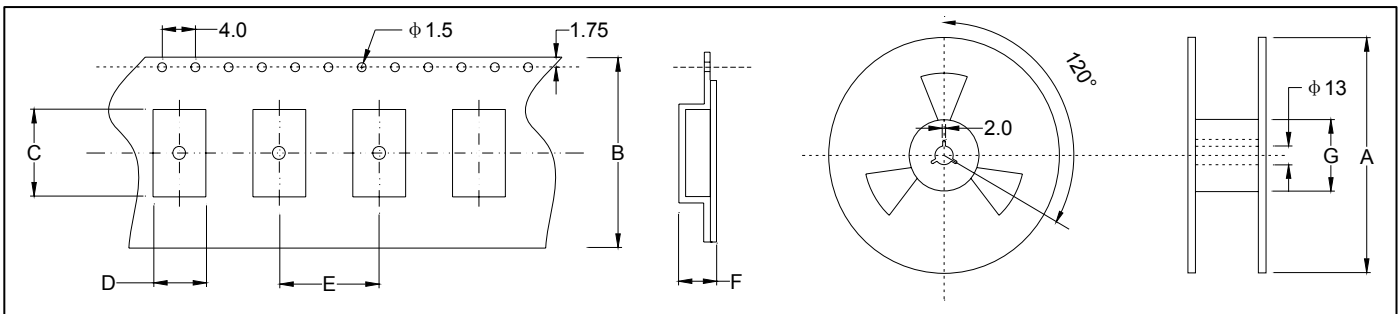

	A	B	C	D	E	F	G
SMD6035	178±2.0	16.0±0.3	6.40±0.10	3.90±0.10	8.0±0.1	1.5±0.1	60.5±1.0
1000 pcs per reel							

★ REFLOW SOLDERING PROFILE 回流焊特性

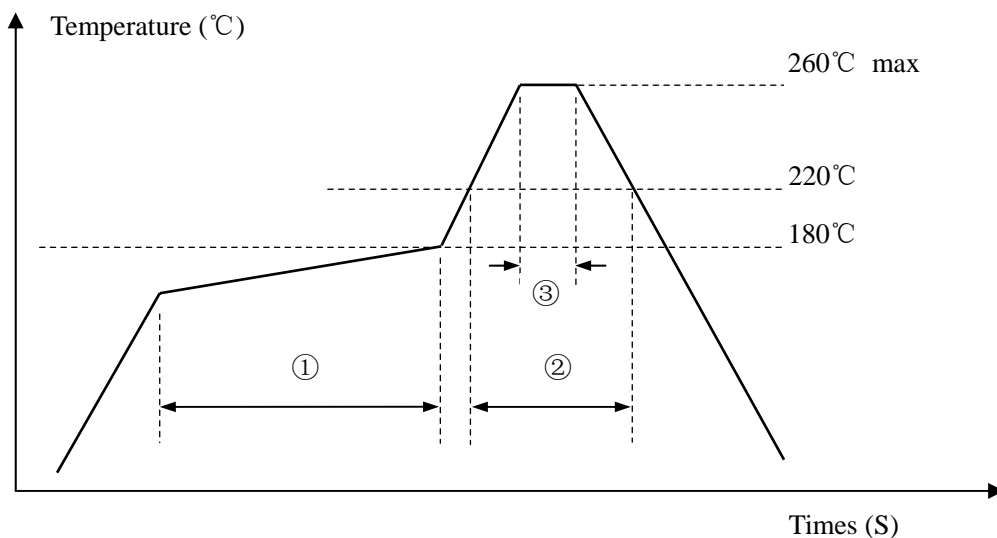

Pb free reflow A	①	Preheat	160~180℃	120sec. max
	②	Primary heat	220℃	60sec. max
	③	Peak	260℃	10sec. max.