



SMD QUARTZ CRYSTAL RESONATOR

石英晶体谐振器



4 Pad Version 8.0×3.8 mm

- Tuning fork crystal in standard package
- 32.768 KHz standard
- ±10 ppm available
- Excellent Reliability Performance
- Reflow soldering temperature: 260°C max



RoHS compliant

★ PARAMETERS

技术参数

PARAMETERS	参数	SPECIFICATION 规格
Frequency Range	频率范围	32.768KHz standard, 20.000~165.000KHz
Loading Capacitance	负载电容	12.5pF Std. 6 to 20pF Series available
Drive Level	激励电平	1.0 μ W Max
Frequency Tolerance	频率偏差	±10ppm ~ ±30ppm (at 25°C)
Equivalent Resistance	谐振电阻	50K Ω Max
Temperature coefficient	温度曲线系数	-0.04×10 ⁻⁶ /°C ² max
Operating Temp. Range:	工作温度范围	-20 ~ +70°C / -40 ~ +85°C
Storage Temp. Range:	储存温度范围	-55 ~ +125°C
Aging (25°C, First Year)	年老化率	±3ppm max

○ All specification subject change without notice. 规格变化, 恕不另行通知。

★ FREQUENCY STABILITY VS. TEMPERATURE 频率温度特性

★ ESR (SERIES RESISTANCE RS)

Operation Temperature Range	Frequency Stability	
	-80ppm	-160ppm
-20°C~+70°C	●	
-40°C~+85°C		●

● standard ○ available

Frequency	20-30KHz	30-40KHz	40-70KHz	z
	50KΩ	45KΩ	20KΩ	12KΩ

★ DIMENSIONS & LAND PATTERN LAYOUT (Unit: mm) 外形尺寸

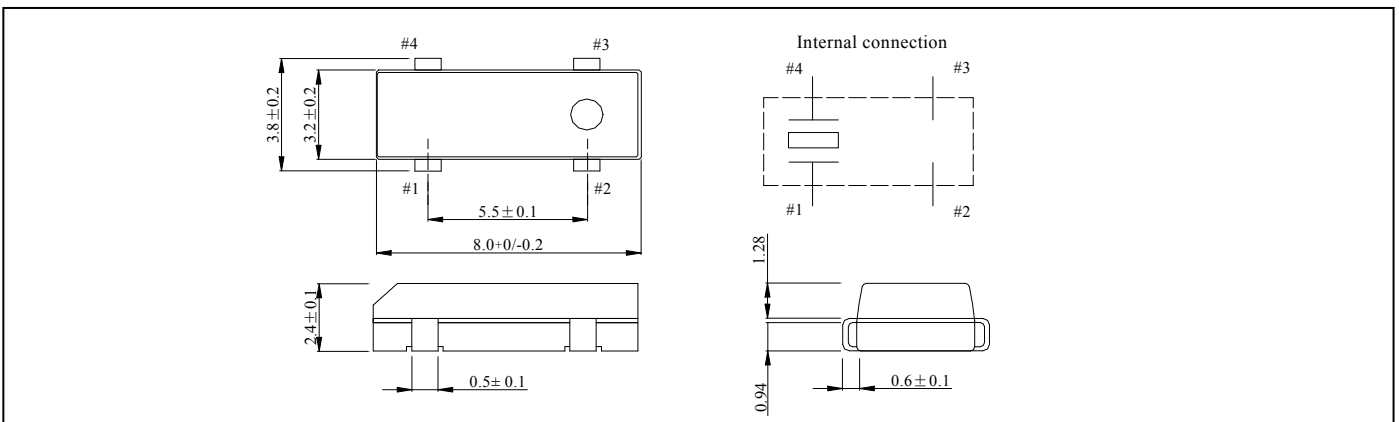

★ PART NUMBER GUIDE 部件号示例 e.g. HLX32.768K12.5SM8 (*SM8=8.0×3.8 SMD)

HL	Quartz Crystal Resonator 石英晶体谐振器	Frequency 频率	Load Capacitance 负载电容	Package 盒型
	X	32.768KHz	12.5	SM8



★ TAPING SPECIFICATION (Unit: mm) 编带规格

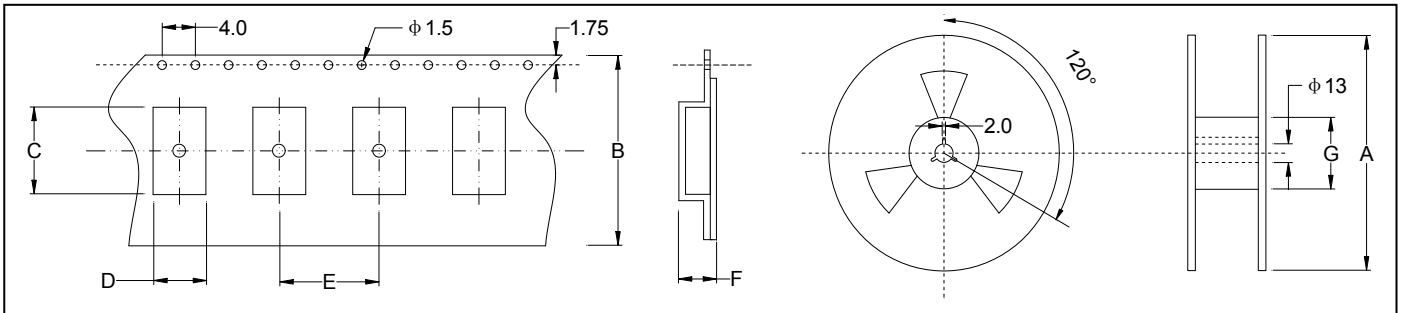

	A	B	C	D	E	F	G
SMD8×3.8	330	16	8.4	4.0	8.0	2.8	100
2000 pcs per reel							

★ REFLOW SOLDERING PROFILE 回流焊特性

