



## SMD QUARTZ CRYSTAL RESONATOR

## 石英晶体谐振器



### 2 Pad Version 2.0×1.2 mm

- Ultra miniature SMD tuning fork crystal resonator
- 32.768 KHz standard
- ±20 ppm Standard
- Excellent Reliability Performance
- Reflow soldering temperature: 260°C max



RoHS compliant

### ★ PARAMETERS

### 技术参数

PARAMETERS	参数	SPECIFICATION 规格
Frequency Range	频率范围	32.768KHz
Loading Capacitance	负载电容	12.5pF Std. 9 pF available
Drive Level	激励电平	0.2μW (1.0μW Max)
Frequency Tolerance	频率偏差	±20ppm (at 25°C)
Equivalent Resistance	谐振电阻	80KΩ Max
Turn-over temperature	/	+25°C±5°C
Temperature coefficient	温度曲线系数	-0.04×10 <sup>-6</sup> /°C <sup>2</sup> max
Operating Temp. Range:	工作温度范围	-40~+85°C
Storage Temp. Range:	储存温度范围	-40~+85°C
Aging (25°C, First Year)	老化率	±3ppm max

○ All specification subject change without notice. 规格变化, 恕不另行通知。

### ★ DIMENSIONS & LAND PATTERN LAYOUT (Unit: mm) 外形尺寸

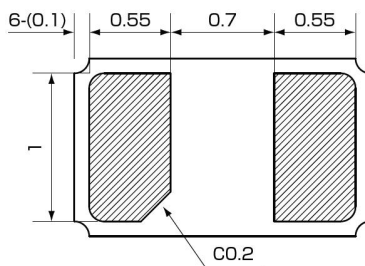
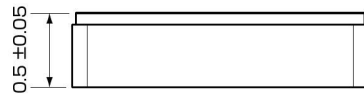
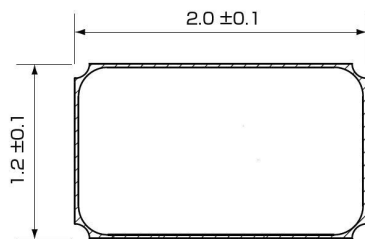

<Top View>

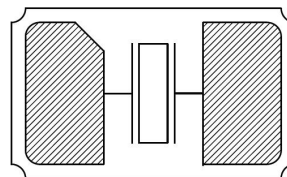

### ■ Recommended Land Pattern [mm]

<Top View>

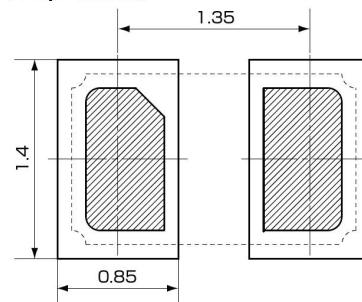

### ★ PART NUMBER GUIDE 部件号示例

e.g. HLX32.768K12.5SM2 (\*SM2=2.0×1.2 SMD)

HL	Quartz Crystal Resonator 石英晶体谐振器	Frequency 频率	Load Capacitance 负载电容	Package 盒型
	X	32.768K	12.5	SM2



★ TAPING SPECIFICATION (Unit: mm) 编带规格

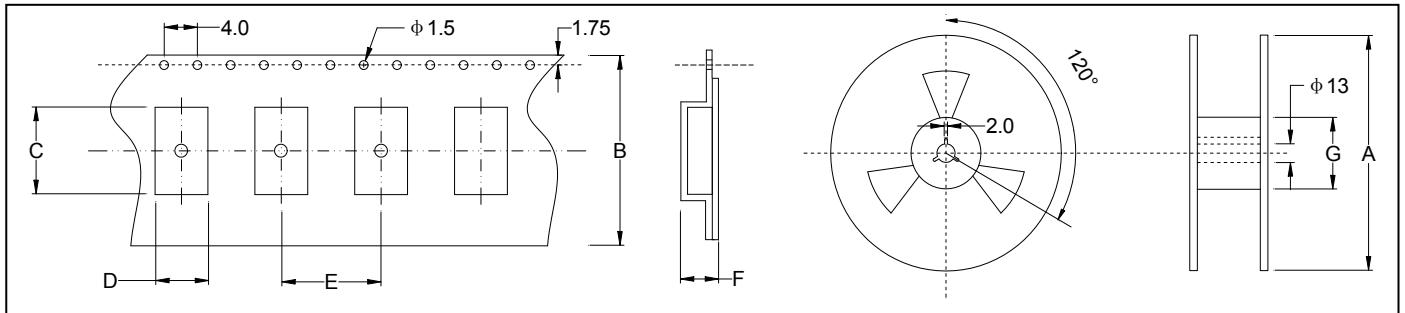

	A	B	C	D	E	F	G
SMD2.0×1.2	180	8.0	2.3	1.45	4.0	0.65	60
3000 pcs per reel							

★ REFLOW SOLDERING PROFILE 回流焊特性

