

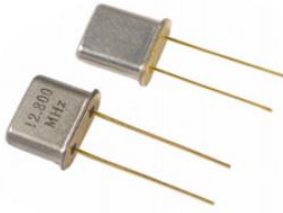

DIP QUARTZ CRYSTAL RESONATOR

石英晶体谐振器



2 Pin Dip Crystal 8.0×3.2 mm UM-1&UM-5

- Resistance welded
- ±2.5ppm available
- Wide frequency range
- AT Cut



RoHS compliant

★ 1. PARAMETERS 技术参数

PARAMETERS	参数	SPECIFICATION 规格
Frequency Range	频率范围	8.0 ~ 200MHz
Operation Mode	振动模式	See Table 3 见表 3
Loading Capacitance	负载电容	20pF Std. 8 to 33pF, Series available
Drive Level	激励电平	100 μ W (500 μ W Max)
Frequency Tolerance	频率偏差	±5ppm ~ ±30ppm (at 25°C)
Equivalent Resistance	谐振电阻	See Table 3 见表 3
Frequency Stability	频率稳定性	±2.5ppm ~ ±30ppm
Operating Temp. Range:	工作温度范围	0 ~ +50°C to -40 ~ +85°C
Storage Temp. Range:	储存温度范围	-55 ~ +125°C

◎ All specification subject change without notice. 规格变化, 恕不另行通知。

★ 2.FREQUENCY STABILITY VS. TEMPERATURE 频率温度特性

Operation Temperature Range	Frequency Stability				
	±2.5ppm	±5ppm	±10ppm	±20ppm	±30ppm
0°C~+50°C	○	○	○	○	○
-10°C~+60°C	○	○	●	○	○
-20°C~+70°C		○	○	●	○
-40°C~+85°C				○	●

● standard ○ available

★ 3. ESR (SERIES RESISTANCE RS)

Frequency	Mode	UM-1 (Ω max)	UM-5 (Ω max)
8.0-15.0MHz	FUND.	40	
15.1-20.0MHz	FUND.	30	40
20.1-30.0MHz	FUND.	25	35
30.1-105.0MHz	3 rd Overtone	45	45
60.0-150.0MHz	5 rd Overtone	100	100
150.0-200.0MHz	7 rd Overtone	150	150

★ PART NUMBER GUIDE 部件号示例 e.g. HLX16.000M20U1-10/10B (*U1=UM-1 U5=UM-5)

Logo	Quartz Crystal Resonator 石英晶体谐振器	Frequency 频率 Hz	Load Capacitance 负载电容 pF	Package 盒型	Frequency Tolerance 常温频差 ppm	Frequency Stability 温度频差 ppm	Operating Temp. Range 工作温度
HL	X	16.000M	20	U1	10	10	B

Definition	Description
Operating Temperature Range	A: 0~+50°C
	B: -10~+60°C
	C: -20~+70°C
	D: -40~+85°C
	E: Customer specified



★ DIMENSIONS (Unit: mm) 外形尺寸

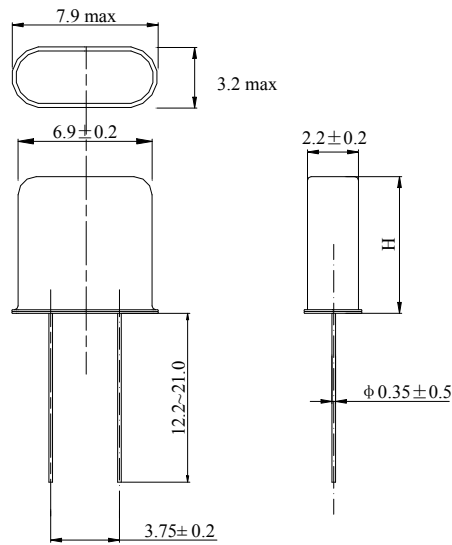

	H
UM-1	8.0 mm max
UM-1	5.8 mm max

★ WAVE SOLDERING PROFILE 波峰焊特性

