

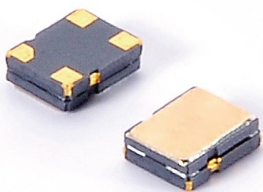

# VCTCXO

# 压控温补振荡器



## 4 Pad Version 3.2×2.5 mm

- ±2.5 ppm stability
- Ultra-miniature package
- Clipped sine wave
- Low power consumption
- Reflow soldering temperature: 260°C max



RoHS compliant

### ★ PARAMETERS 技术参数

PARAMETERS	参数	SPECIFICATION 规格	
Frequency Range	频率范围	10.0~40.0MHz	
Supply Voltage	工作电压	1.8V、2.5V、2.8V、3.3V	
Supply Current	输入电流	10MHz≤F0≤26MHz: 2.0mA max 26MHz<F0≤40MHz: 2.5mA max	
Frequency Tolerance	调整频差	±0.5ppm、±1.0ppm、±2.0ppm	
Frequency Stability	频率稳定性	Vs Temperature (ref. to +25°C)	±1.5~±2.5ppm
		Vs Supply voltage change (±5%)	±0.2ppm
		Vs Load change (±10%)	±0.2ppm
		Vs Aging (1 <sup>st</sup> Year ,25±2°C)	±1.0ppm
Operating Temp. Range	工作温度范围	-30~+85°C	
Storage Temp. Range	储存温度范围	-55~+125°C	
Voltage Control Range	压控范围	±5.0ppm min	
Output Waveform:	输出波形	Clipped Sine Wave	
Output Level:	输出电平	0.8 Vp-p Min (Clipped Sine Wave)	
Output Load	输出负载	10K Ω //10pF	
Symmetry	占空比	45% ~ 55% typ. at 0.5×Vdc	
Start-up Time	起振时间	2.0mS max	
Phase Noise	相位噪声	-115 dBc/Hz max @100Hz offset	
		-135 dBc/Hz max @1KHz offset	
		-148 dBc/Hz max @10KHz offset	

© All specification subject change without notice. 规格变化，恕不另行通知。

### ★ DIMENSIONS & LAND PATTERN LAYOUT (Unit: mm) 外形尺寸

Pin	Connection
1	Vcon
2	GND
3	Output
4	V <sub>DC</sub>

Recommended land Pattern

### ★ PART NUMBER GUIDE 部件号示例 e.g. HVTO26.000ACC2.8SM3 (\*SM3=3.2×2.5 SMD TYPE)

	VCTCXO 压控温补振荡器	Frequency 频率	Frequency Tolerance 调整频差	Frequency Stability 频率稳定度	Operating Temp. 工作温度	Supply voltage 工作电压	Package 盒型
H	VTO	26.000	A	C	C	2.8	SM3



Definition	Description	Definition	Description
Frequency Stability 频率稳定度	A: $\pm 1.5\text{ppm}$	Operating Temp. 工作温度	A: $-10\sim+70^{\circ}\text{C}$
	B: $\pm 2.0\text{ppm}$		B: $-20\sim+80^{\circ}\text{C}$
	C: $\pm 2.5\text{ppm}$		C: $-30\sim+85^{\circ}\text{C}$
	D: Customer specified		D: Customer specified

★ TEST CIRCUIT 测试原理图

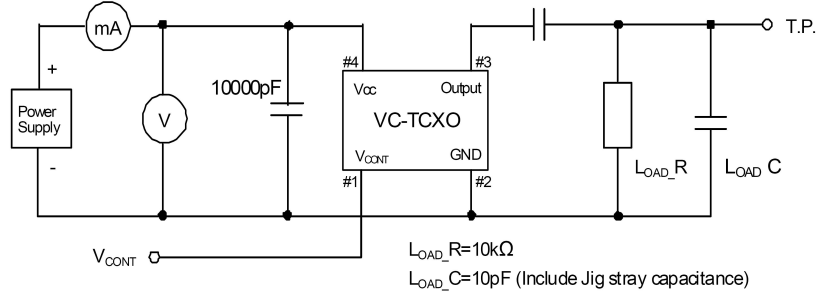

★ TAPING SPECIFICATION (Unit: mm) 编带规格

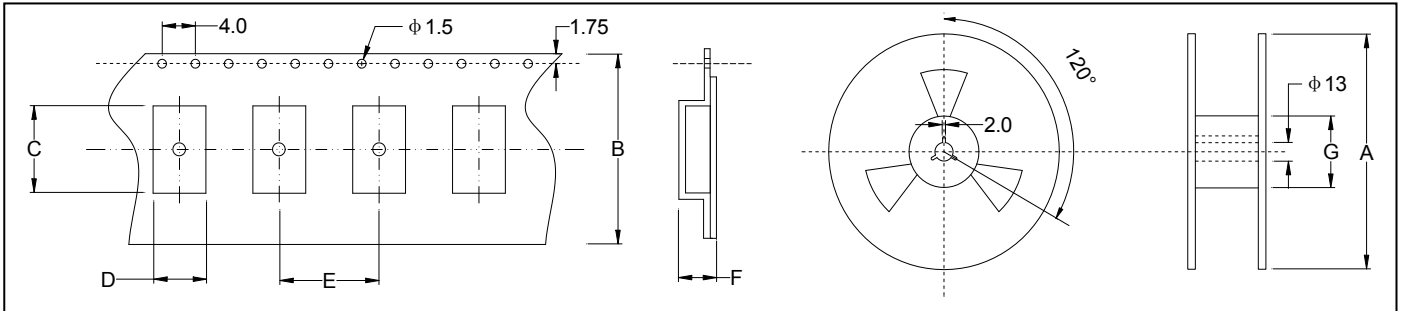

	A	B	C	D	E	F	G
OSC-SMD3225	$178\pm 2.0$	$8.0\pm 0.3$	$3.55\pm 0.10$	$2.80\pm 0.10$	$4.0\pm 0.1$	$1.4\pm 0.1$	$60.5\pm 1.0$
3000 pcs per reel							

★ REFLOW SOLDERING PROFILE 回流焊特性

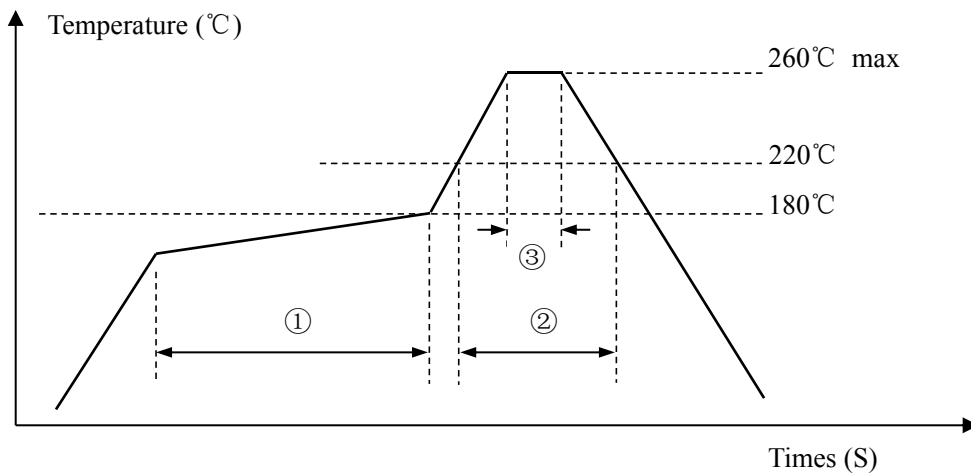

Pb free reflow A	①	Preheat	160~180°C	120sec. max
	②	Primary heat	220°C	60sec. max
	③	Peak	260°C	10sec. max.