

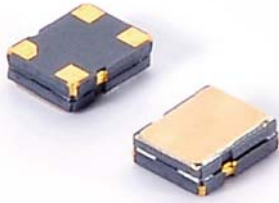

SMD QUARTZ CRYSTAL OSCILLATOR

石英晶体振荡器



4 Pad Version 2.5x2.0 mm

- ±20 ppm type available
- Excellent Reliability Performance
- EMI shielding possible by grounded lid
- Reflow soldering temperature: 260°C max
- Ceramic Seam Weld package



RoHS compliant

★ PARAMETERS 技术参数

PARAMETERS	参数	SPECIFICATION 规格
Frequency Range	频率范围	2~50MHz
Supply voltage	工作电压	1.8V、2.5V、2.8V、3.3V
Input Current	输入电流	See Below
Frequency Stability Overall	频率稳定性	±20ppm~±50ppm
Operating Temp. Range	工作温度范围	-10~+60°C to -40~+85°C
Storage Temp. Range	储存温度范围	-55~+125°C
Output Load	输出负载	HCMOS/TTL (15pF~30pF/10TTL)
Symmetry	占空比	45% ~ 55% typ. (40% ~ 60% max.) at 0.5×Vdc
Start-up time	起振时间	10mS max
Enable/ Disable Function	三态控制	O/E or E/D

◎ All specification subject change without notice. 规格变化, 恕不另行通知。

★ FREQUENCY STABILITY VS. TEMPERATURE 频率温度特性

Operation Temperature Range	Frequency Stability			
	±20ppm	±25ppm	±30ppm	±50ppm
-10°C~+60°C	○	●	○	○
-20°C~+70°C	○	○	●	○
-40°C~+85°C				●

● standard ○ available

★ Rise & Fall TIME MAX. 上升/下降时间

Frequency	Rise & Fall Time	V _{DC}	Rise & Fall Time	V _{DC}
2.0~9.9 MHz	5nS max	3.3V	6nS max	1.8V
10.0~19.9 MHz	5nS max		5nS max	
20.0~31.9 MHz	5nS max		4nS max	
32.0~50MHz	5nS max		4nS max	

★ DIMENSIONS & LAND PATTERN LAYOUT (Unit: mm) 外形尺寸

Pin	Connection
1	Tri-state or no connect
2	GND
3	Output
4	V _{DC}

Recommended land Pattern

★ PART NUMBER GUIDE 部件号示例 e.g. HXO12.000AA3.3SM3 (*SM3=3.2×2.5 SMD TYPE)

	Quartz Crystal Oscillator 石英晶体振荡器	Frequency 频率	Frequency Stability 频率稳定度	Operating Temp. 工作温度	Supply voltage 工作电压	Package 盒型
H	XO	12.000	A	A	3.3	SM2



Definition	Description	Definition	Description
Frequency Stability 频率稳定度	A: $\pm 25\text{ppm}$	Operating Temp. 工作温度	A: $0\sim+70^{\circ}\text{C}$
	B: $\pm 50\text{ppm}$		B: $-20\sim+70^{\circ}\text{C}$
	C: $\pm 100\text{ppm}$		C: $-40\sim+85^{\circ}\text{C}$
	D: Customer specified		D: Customer specified

★ INPUT CURRENT 工作电流

Vdc=3.3V		Vdc=2.5V		Vdc=1.8V	
2.0 ~ 9.9 MHz	7 mA	2.0 ~ 9.9 MHz	6 mA	2.0 ~ 9.9 MHz	3 mA
10.0 ~ 19.9 MHz	7 mA	10.0 ~ 19.9 MHz	8 mA	10.0 ~ 19.9 MHz	5 mA
20.0 ~ 31.9 MHz	12 mA	20.0 ~ 31.9 MHz	8 mA	20.0 ~ 31.9 MHz	5 mA
32.0 ~ 50.0 MHz	20 mA	32.0 ~ 50.0 MHz	20 mA	32.0 ~ 50.0 MHz	10 mA

★ TAPING SPECIFICATION (Unit: mm) 编带规格

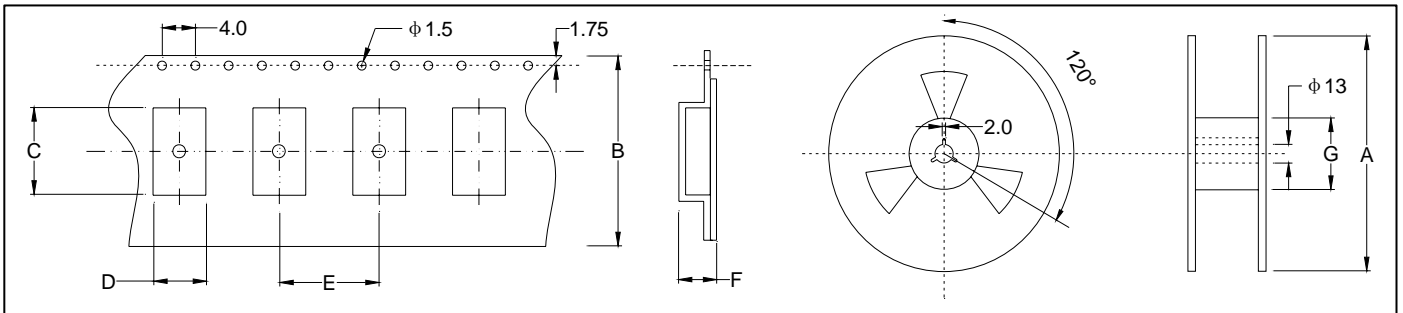

	A	B	C	D	E	F	G
OSC-SMD2520	178 ± 2.0	8.0 ± 0.2	2.80 ± 0.10	2.30 ± 0.10	4.0 ± 0.1	1.15 ± 0.1	60.5 ± 1.0
3000 pcs per reel							

★ REFLOW SOLDERING PROFILE 回流焊特性

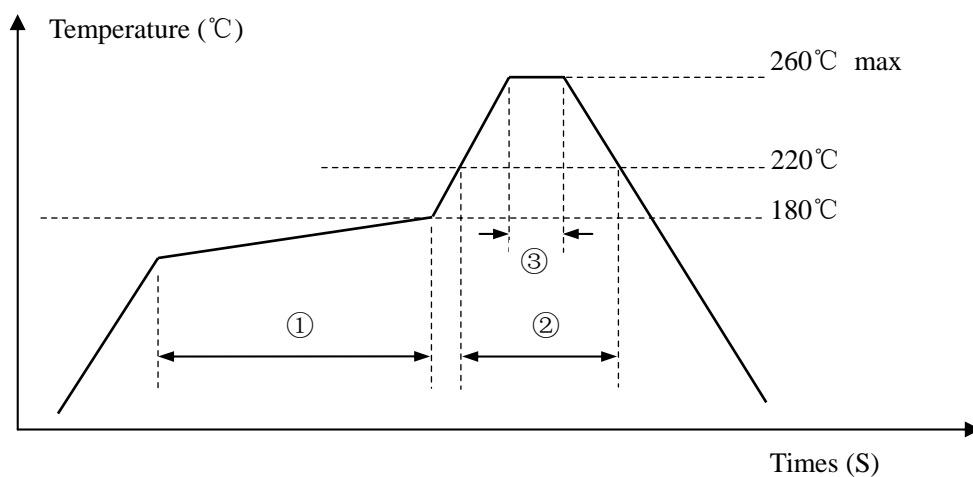

Pb free reflow A	①	Preheat	160~180°C	120sec. max
	②	Primary heat	220°C	60sec. max
	③	Peak	260°C	10sec. max.