

Ordering Information:

C3030HMB-2xXP - **
1 2

1.Part No.

2.Material:

(blank):Nylon 66 UL94V-0

GWT:Nylon 66 UL94V-0,GWT 750°C

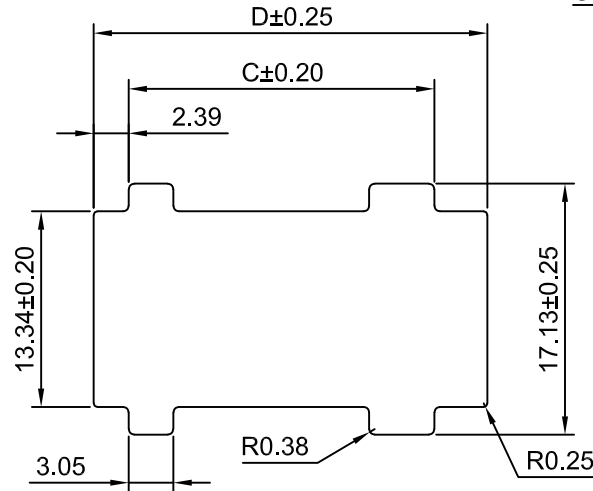
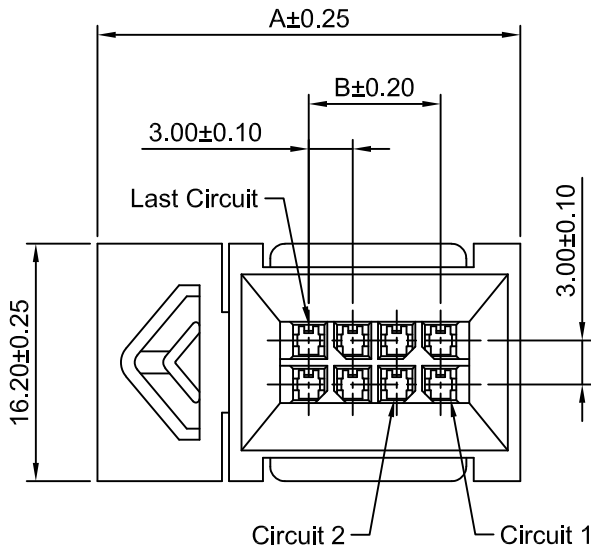
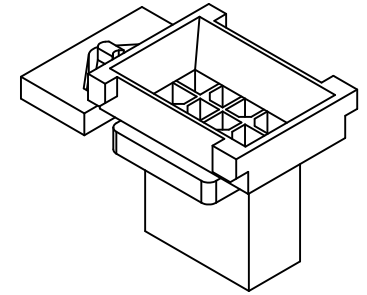

PANEL OPENING
RECOMMENDED PANEL THICKNESS
1.57/1.27

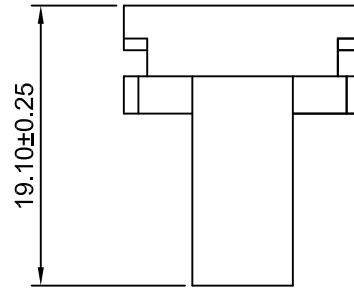
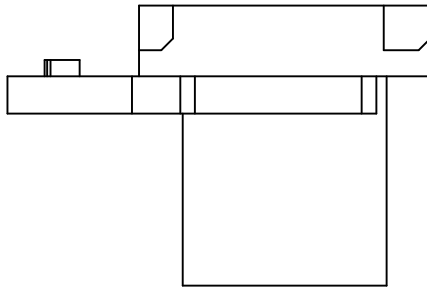

SPECIFICATIONS:

Current Rating: 12.5A AC,DC (AWG #18)

Voltage Rating: 600V AC,DC

Temperature Range: -40°C ~ +105°C

Contact Resistance: 10mΩ Max

Insulation Resistance: 1000MΩ Min

Withstanding Voltage: 1500V AC/minute

Material: Nylon 66,UL94V-0(Black)

Ordering Information & Dimensions

Circuits	Dimensions(mm)			
	A	B	C	D
2x2P	22.84	3.00	14.85	20.85
2x3P	25.84	6.00	17.85	23.85
2x4P	28.84	9.00	20.85	26.85
2x5P	31.84	12.00	23.85	29.85
2x6P	34.84	15.00	26.85	32.85
2x7P	37.84	18.00	29.85	35.85
2x8P	40.84	21.00	32.85	38.85
2x9P	43.84	24.00	35.85	41.85
2x10P	46.84	27.00	38.85	44.85
2x11P	49.84	30.00	41.85	47.85
2x12P	52.84	33.00	44.85	50.85

Beijing Hongli Kunpeng International Trade Co., Ltd.

Unit	Scale	Sheet	TITLE
mm	2:1	1 of 1	
DRWN	CHK'D	APPR	3.00mm PITCH
Xu Lei	Diankui Wan	Jack Yin	
General Tolerances			Dual Row HOUSING
THIRD ANGLE PROJECTION			
DRAWING NO.			REV A2
HLB-30-HMB-2xXP 37			

A2	CHANGE THE DRAWING	2022.01.14
A1	CHANGE THE Current Rating	2018.12.15
A0	NEW RELEASE	2009.05.10
REV	DESCRIPTION	DATE

x.x±0.25
x.xx±0.20
x.xxx±0.15
ANGLES ±1°

