

Ordering Information:  
 C3030WV-F-2xXP - \*\*\* - \*\*\* - \*\*\*  
 1 2 3 4

- Part No.
- Size(H):  
 (blank):2.00mm  
 H30:3.00mm
- Material:  
 (blank):Nylon 66 UL94V-0  
 LCP:LCP UL94V-0  
 GWT:LCP UL94V-0,GWT 750°C
- Finish:  
 (blank):Tin over Nickel  
 G:Gold over Nickel(1"U)  
 G3:Gold over Nickel(3"U)  
 G15:Gold over Nickel(15"U)  
 G30:Gold over Nickel(30"U)

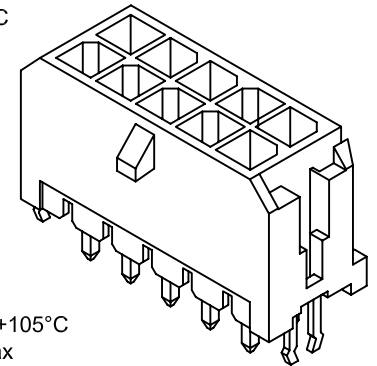

**SPECIFICATIONS:**  
 Current Rating: 5A AC,DC  
 Voltage Rating: 250V AC,DC  
 Temperature Range: -40°C ~ +105°C  
 Contact Resistance: 10mΩ Max  
 Insulation Resistance: 1000MΩ Min  
 Withstanding Voltage: 1500V AC/minute  
 Pin Material: Brass/Tin over Nickel  
 Material: Nylon 66,UL94V-0(Black)

Ordering Information & Dimensions

Circuits	Dimensions(mm)			Circuits	Dimensions(mm)		
	A	B	C		A	B	C
2x1P	—	6.65	4.30	2x7P	18.00	24.65	22.30
2x2P	3.00	9.65	7.30	2x8P	21.00	27.65	25.30
2x3P	6.00	12.65	10.30	2x9P	24.00	30.65	28.30
2x4P	9.00	15.65	13.30	2x10P	27.00	33.65	31.30
2x5P	12.00	18.65	16.30	2x11P	30.00	36.65	34.30
2x6P	15.00	21.65	19.30	2x12P	33.00	39.65	37.30

Beijing Hongli Kungpeng International Trade Co., Ltd.

Unit	Scale	Sheet
mm	4:1	1 of 1
Draw BY:	Approved :	
Tony Su	Jack Yin	

Title :  
**3.00mm PITCH  
 180° DUAL ROW  
 WAFER - SMT TYPE**

REV	DESCRIPTION	DATE	General Tolerance	ANGLE±
A1	Update drawings	2011.12.14	x.xx≤0.25	
A0	NEW RELEASE	2009.05.10	x.xx≤0.20	
			x.xxx≤0.15	

DRAW NO : HLB-30-WV-F-2xXP 7 | REV A1