

Ordering Information:

C3030WV-S-2xXP - ***

1 2

1.Part No.

2.Pin Finish:

(blank): Tin over Nickel

G: Gold over Nickel

G3: Gold over Nickel

G15: Gold over Nickel(Au:15u",Mating Area)

G30: Gold over Nickel(Au:30u",Mating Area)

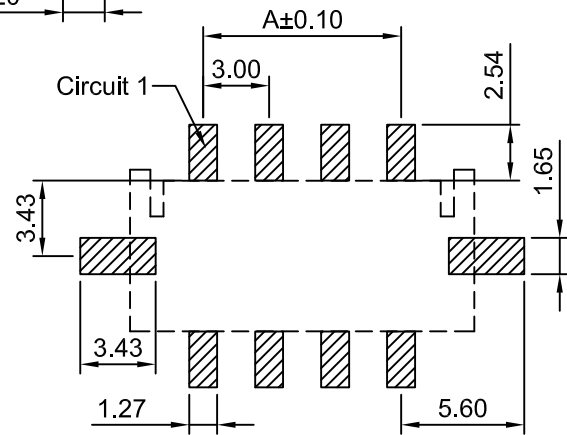
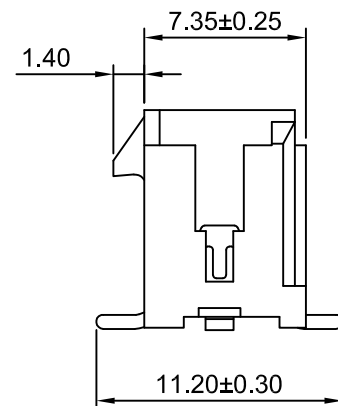
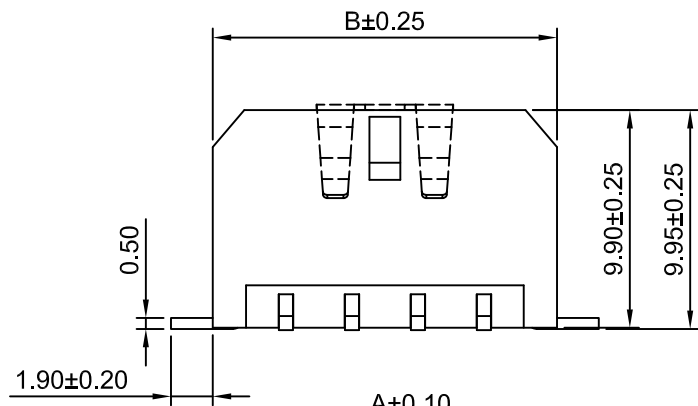
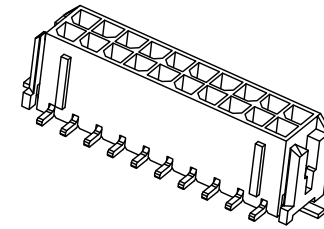

P.C.B LAYOUT (TOP VIEW)
TOLERANCE:±0.05

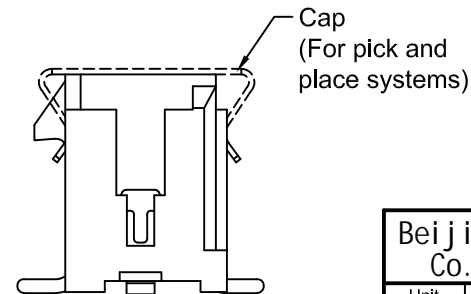

SPECIFICATIONS:

Current Rating: 12.5A AC,DC (AWG #18)

Voltage Rating: 600V AC,DC

Temperature Range: -40°C ~ +105°C

Contact Resistance: 10mΩ Max

Insulation Resistance: 1000MΩ Min

Withstanding Voltage: 1500V AC/minute

Pin Material: Brass/Tin over Nickel

Solder tabs: Brass/Tin over Nickel

Material: LCP,UL94-V0(Black)

Ordering Information & Dimensions

Part No.	Dimensions(mm)	
	A	B
C3030WV-S-2x1P	---	6.70
C3030WV-S-2x2P	3.00	9.70
C3030WV-S-2x3P	6.00	12.70
C3030WV-S-2x4P	9.00	15.70
C3030WV-S-2x5P	12.00	18.70
C3030WV-S-2x6P	15.00	21.70
C3030WV-S-2x7P	18.00	24.70
C3030WV-S-2x8P	21.00	27.70
C3030WV-S-2x9P	24.00	30.70
C3030WV-S-2x10P	27.00	33.70
C3030WV-S-2x11P	30.00	36.70
C3030WV-S-2x12P	33.00	39.70

Beijing Hongli Kunpeng International Trade Co., Ltd.

Unit	Scale	Sheet	TITLE
mm	3:1	1 of 2	3.00mm PITCH VERTICAL DUAL ROW WAFER -SMD TYPE
DRN	CHK	APVD	
Xu Lei	DianKui Wan	Jack Yin	
General Tolerance			THIRD ANGLE PROJECTION
x.xx±0.25 x.xxx±0.20 x.xxxx±0.15 ANGLES ±1°			DRAWING NO HLB-30-WV-S-2xXP 6
REV			REV A3

REV	DESCRIPTION	DATE
A3	CHANGE THE DRAWING	2022.01.14
A2	CHANGE THE DRAWING	2020.05.28
A1	CHANGE THE Current Rating	2018.12.26
A0	NEW RELEASE	2012.12.06

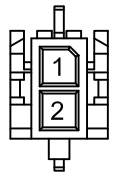

2x1P

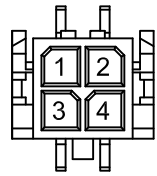

2x2P

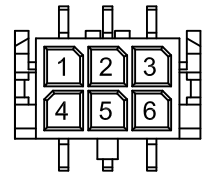

2x3P

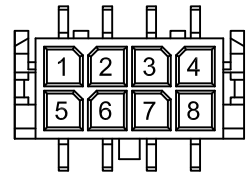

2x4P

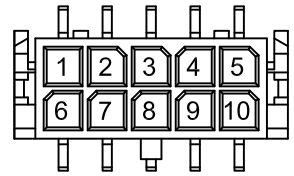

2x5P

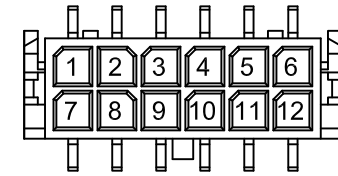

2x6P

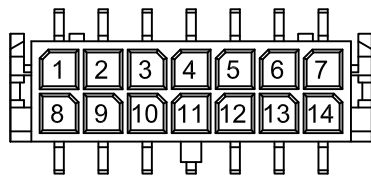

2x7P

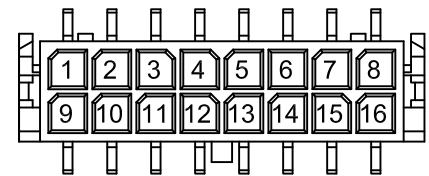

2x8P

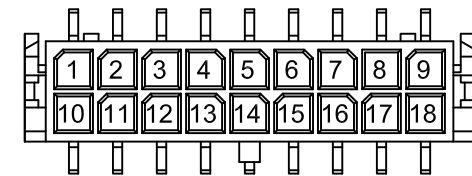

2x9P

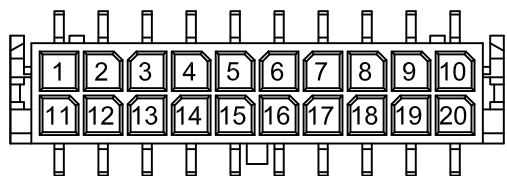

2x10P

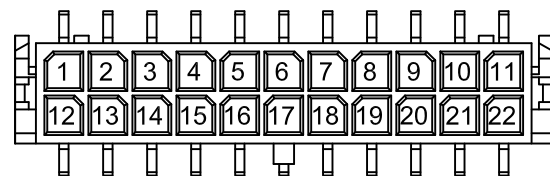

2x11P

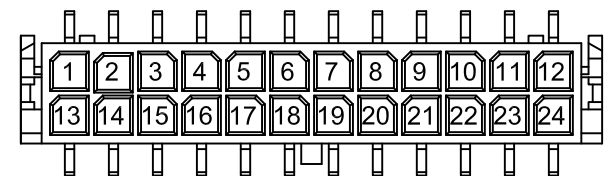

2x12P

Beijing Hongli Kungpeng International Trade Co., Ltd.

Unit	Scale	Sheet	TITLE
mm	3:1	2 of 2	3.00mm PITCH VERTICAL DUAL ROW WAFER -SMD TYPE
DRN	CHK	APVD	
Xu Lei	DlanKul Wan	Jack Yin	DRAWING NO
General Tolerance			THIRD ANGLE PROJECTION
x.xx±0.25 x.xxx±0.20 x.xxxx±0.15 ANGLES ±1°			HLB-30-WV-S-2xXP 6
REV			REV
DESCRIPTION			A3

A3	CHANGE THE DRAWING	2022.01.14
A2	CHANGE THE DRAWING	2020.05.28
A1	CHANGE THE Current Rating	2018.12.26
A0	NEW RELEASE	2012.12.06
REV	DESCRIPTION	DATE