

P.C.B LAYOUT  
TOLERANCE:±0.05

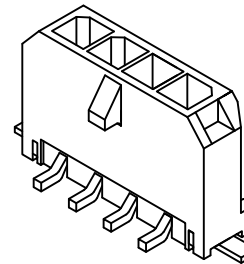

Ordering Information:  
C3030WV-S-XP - \*\*\* - \*\*  
1 2 3

- Part NO.
- Material:  
(blank):LCP UL94V-0  
GWT:LCP UL94V-0,IEC 60335-1,5th Edition  
Glow Wire Capable.
- Finish:  
(blank):Tin over Nickel  
G:Gold over Nickel(1u")  
G15:Gold over Nickel(Au:15u",Mating Area)  
G30:Gold over Nickel(Au:30u",Mating Area)

**SPECIFICATIONS:**

Current Rating: 12.5A AC,DC (AWG #18)  
Voltage Rating: 600V AC,DC  
Temperature Range: -40°C ~ +105°C  
Contact Resistance: 10mΩ Max  
Insulation Resistance: 1000MΩ Min  
Withstanding Voltage: 1500V AC/minute  
Pin Material: Brass/Tin over Nickel  
Material: LCP,UL94V-0 (Black)

Ordering Information & Dimensions

Part NO.	Dimensions(mm)		
	A	B	C
C3030WV-S-2P	3.00	9.65	14.20
C3030WV-S-3P	6.00	12.65	17.20
C3030WV-S-4P	9.00	15.65	20.20
C3030WV-S-5P	12.00	18.65	23.20
C3030WV-S-6P	15.00	21.65	26.20
C3030WV-S-7P	18.00	24.65	29.20
C3030WV-S-8P	21.00	27.65	32.20
C3030WV-S-9P	24.00	30.65	35.20
C3030WV-S-10P	27.00	33.65	38.20
C3030WV-S-11P	30.00	36.65	41.20
C3030WV-S-12P	33.00	39.65	44.20

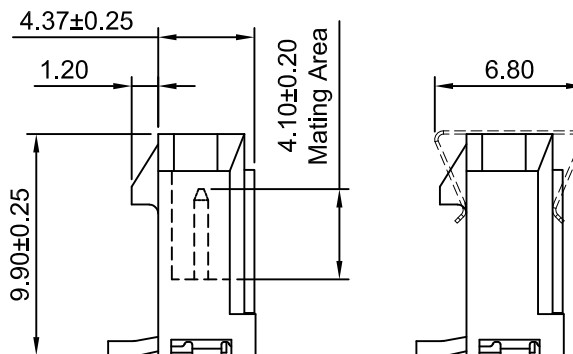
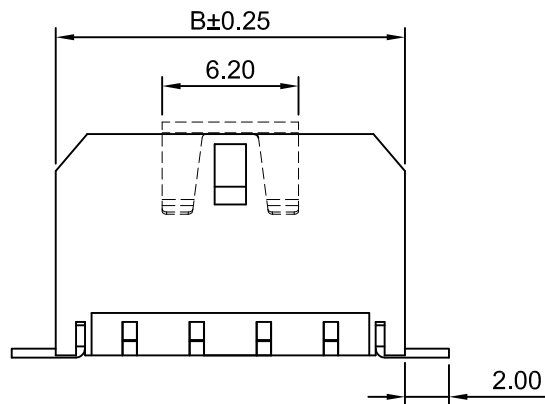

WITH CAP

A3	CHANGE THE DRAWING	2022.01.14
A2	CHANGE THE DRAWING	2020.08.04
A1	CHANGE THE CURRENT RATING	2018.12.26
A0	NEW RELEASE	2005.05.10
REV	DESCRIPTION	DATE

Beijing Hongli Kunpeng International Trade Co., Ltd.

Unit	Scale	Sheet	TITLE
mm	3:1	1 of 1	3.00mm PITCH VERTICAL SINGLE ROW WAFER - SMD TYPE
DRWN	CHK'D	APPR	
Xu Lei	Diankui Wan	Jack Yin	DRAWING NO.
General Tolerances			THIRD ANGLE PROJECTION
x.xx±0.25 x.xxx±0.20 x.xxxx±0.15 ANGLES ±1°			HLB-30-WV-S-XP 3
			REV A3