

SEC: A-A

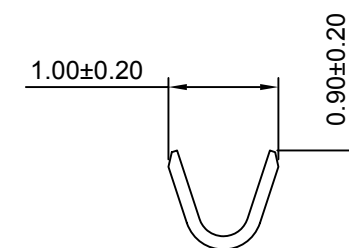

SEC: B-B

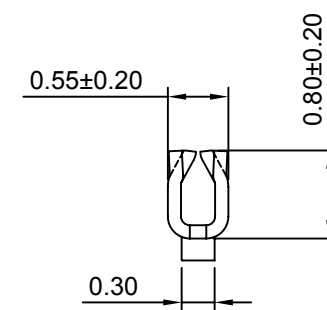

SEC: C-C

Beijing Hongli Kumpeng International Trade Co., Ltd.

Ordering information & Specifications

Unit:mm

Part No	Wire Range	Insultion O.D.	Material	Finish	Qty/reel
A0801-TP	AWG#28-#32	0.60mm(max)	Phosphor Bronze	Tin over Nickel	45,000 PCS
A0801-GP	AWG#28-#32	0.60mm(max)	Phosphor Bronze	Gold over Nickel	45,000 PCS

Optional Gold plating available but MOQ requested

Unit mm	Scale 15:1	Sheet 1 of 1
------------	---------------	-----------------

Title :

0.80mm PITCH

Draw BY: Jack Yin	Approved : GONGYB
----------------------	----------------------

CRIMP TERMINAL

General Tolerance

A0	NEW RELEASE	2014.12.10	x.xx≤0.25 x.xxx≤0.20 x.xxxx≤0.15	ANGLE±
REV	DESCRIPTION	DATE		

DRAW NO : HLB-01-T 4

REV
A0