

SEC: A-A

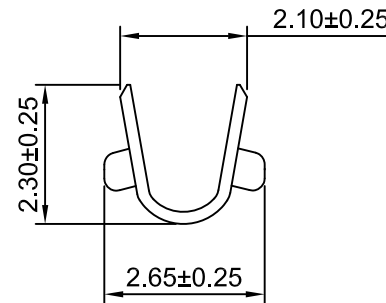

SEC: B-B

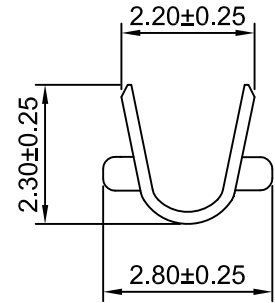

SEC: C-C

Ordering information & Specifications

Unit:mm

Part No	Wire Range	Insulation O.D.	Material	Finish	PCB Thickness	PCB Hole Diameter	Qty/reel
B1801-TB	AWG#18-#22	2.10mm(max)	Brass	Tin over Nickel	1.60mm(Max)	1.80mm	7,000 PCS
B1801-TP	AWG#18-#22	2.10mm(max)	Phosphor Bronze	Tin over Nickel	1.60mm(Max)	1.80mm	7,000 PCS
B1801-GB	AWG#18-#22	2.10mm(max)	Brass	Gold over Nickel	1.60mm(Max)	1.80mm	7,000 PCS
B1801-GP	AWG#18-#22	2.10mm(max)	Phosphor Bronze	Gold over Nickel	1.60mm(Max)	1.80mm	7,000 PCS

Beijing Hongli Kunpeng International Trade Co., Ltd.

Unit	Scale	Sheet	Title :		
mm	8:1	1 of 1	1.80mm Pitch		
Draw By:		Approved :			
Diankui Wan		Jack Yin			
General Tolerance					
A1	CHANGE THE INFORMATION	2019.06.29	x.xx±0.25	PROJECT	
A0	NEW RELEASE	2009.05.10	x.xx±0.20		
REV	DESCRIPTION	DATE	x.xxx±0.15		
DRAW NO :				HLB-01-T 1	REV A1