

SEC:A-A

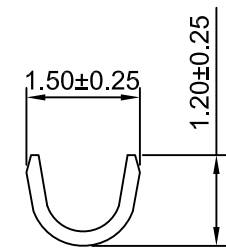

SEC:B-B

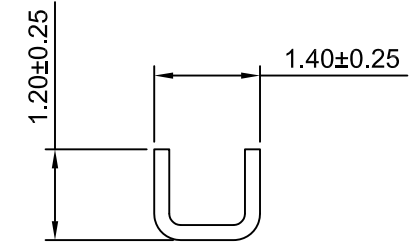

SEC:C-C

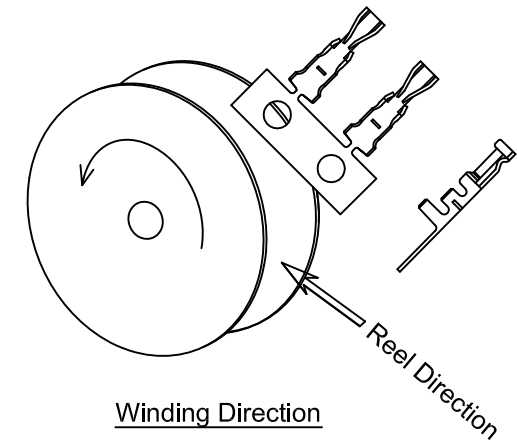

Ordering information & Specifications

Unit:mm

Part No	Wire Range	Insulation O.D.	Material	Finish	Qty/reel
A2005-TB-D	AWG#22-#28	1.40mm(max)	Brass	Tin over Nickel	10,000 PCS
A2005-GB-D	AWG#22-#28	1.40mm(max)	Brass	Gold over Nickel	10,000 PCS
A2005-TP-D	AWG#22-#28	1.40mm(max)	Phosphor Bronze	Tin over Nickel	10,000 PCS
A2005-GP-D	AWG#22-#28	1.40mm(max)	Phosphor Bronze	Gold over Nickel	10,000 PCS

REV	DESCRIPTION	DATE
A0	NEW RELEASE	2021.03.12

Beijing Hongli Kumpeng International Trade Co., Ltd.

Unit	Scale	Sheet	TITLE
mm	10:1	1 of 1	2.00mm PITCH CRIMP TERMINAL
DRWN	CHK'D	APPR	
Dengchun Yi	Diankui Wan	Jack Yin	DRAWING NO. HLB-05-T-D 88
General Tolerances	THIRD ANGLE PROJECTION		
x.xx±0.25 x.xxx±0.20 x.xxx±0.15 ANGLES ±1°			