

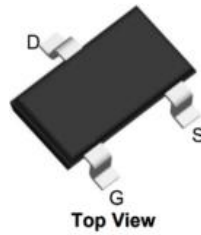

## P-Channel Enhancement Mode MOSFET

### Features

- Advanced Trench Process Technology
- Low Threshold Voltage
- Fast Switching Speed
- Halogen-Free & Lead-Free



Top View

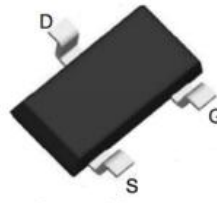

Bottom View

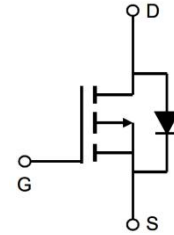

### Application

- Load Switch for Portable Devices
- Voltage controlled small signal switch

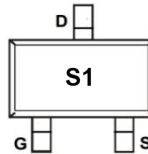

SOT-23  
Marking: S1

### Absolute Maximum Ratings (at Ta = 25°C unless otherwise specified)

Parameter	Symbol	Value	Unit
Drain-Source Voltage	$V_{DS}$	-20	V
Gate-Source Voltage	$V_{GS}$	$\pm 12$	V
Continuous Drain Current	$I_D$	-2.3	A
Peak Drain Current, Pulsed <sup>1)</sup>	$I_{DM}$	-10	A
Power Dissipation	$P_{tot}$	1.25	W
Operating Junction and Storage Temperature Range	$T_J - T_{stg}$	-55~150	°C

### Thermal Characteristics

Parameter	Symbol	Max.	Unit
Thermal Resistance from Junction to Ambient <sup>2)</sup>	$R_{\theta JA}$	100	°C/W

Note:

1) Pulse width  $\leq 100\mu s$ , duty cycle  $\leq 1\%$ , limited by  $T_{jmax}$ .

2) Device mounted on FR-4 substrate PC board, 2ozcopper, with 1-inch square copper plate in still air.



**Characteristics at Ta = 25°C unless otherwise specified**

Parameter	Symbol	Min.	Typ.	Max.	Unit
<b>STATIC PARAMETERS</b>					
Drain-Source Breakdown Voltage at $I_D = -250 \mu A$	$BV_{DSS}$	-20			V
Drain-Source Leakage Current at $V_{DS} = -20 V$	$I_{DSS}$			-1	$\mu A$
Gate Leakage Current at $V_{GS} = \pm 12 V$	$I_{GSS}$			$\pm 100$	nA
Gate-Source Threshold Voltage at $V_{DS} = V_{GS}, I_D = -250 \mu A$	$V_{GS(th)}$	-0.4	-0.7	-1	V
Drain-Source On-State Resistance at $-V_{GS} = 4.5 V, -I_D = 2.5 A$ at $-V_{GS} = 2.5 V, -I_D = 2 A$	$R_{DS(on)}$		86 124	100 140	m $\Omega$
<b>DYNAMIC PARAMETERS</b>					
Gate resistance at $V_{DS} = 0 V, V_{GS}=0V, f = 1 MHz$	$R_g$		7		$\Omega$
Forward Transconductance at $V_{DS} = -5V, I_D = -2 A$	$g_{fs}$		8		S
Input Capacitance at $V_{DS} = -10V, V_{GS} = 0 V, f = 1 MHz$	$C_{iss}$		354		pF
Output Capacitance at $V_{DS} = -10V, V_{GS} = 0 V, f = 1 MHz$	$C_{oss}$		48		pF
Reverse Transfer Capacitance at $V_{DS} = -10V, V_{GS} = 0 V, f = 1 MHz$	$C_{rss}$		28		pF
Gate charge total at $V_{DS} = -10 V, I_{DS} = -1 A, V_{GS} = -4.5 V$	$Q_g$		4.9		nC
Gate to Source Charge at $V_{DS} = -10 V, I_{DS} = -1 A, V_{GS} = -4.5 V$	$Q_{gs}$		1.4		nC
Gate to Drain Charge at $V_{DS} = -10 V, I_{DS} = -1 A, V_{GS} = -4.5 V$	$Q_{gd}$		1.3		nC
Turn-On Delay Time at $V_{DD} = -10 V, I_{DS} = -1 A, R_g = 10 \Omega, V_{GS} = -4.5 V$	$t_{d(on)}$		8.4		nS
Turn-On Rise Time at $V_{DD} = -10 V, I_{DS} = -1 A, R_g = 10 \Omega, V_{GS} = -4.5 V$	$t_r$		11.8		nS
Turn-Off Delay Time at $V_{DD} = -10 V, I_{DS} = -1 A, R_g = 10 \Omega, V_{GS} = -4.5 V$	$t_{d(off)}$		32.4		nS
Turn-Off Fall Time at $V_{DD} = -10 V, I_{DS} = -1 A, R_g = 10 \Omega, V_{GS} = -4.5 V$	$t_f$		17.8		nS
<b>Body-Diode PARAMETERS</b>					
Drain-Source Diode Forward Voltage at $-I_S = 0.75 A, V_{GS} = 0 V$	$V_{SD}$			1.2	V
Reverse Recovery Time at $I_F = 1 A, di_{SD}/dt = 100 A/\mu s$	$t_{rr}$		5.3		nS
Reverse Recovery Charge at $I_F = 1 A, di_{SD}/dt = 100 A/\mu s$	$Q_{rr}$		1.7		nC



Electrical Characteristics Curves

Fig. 1 Typical Output Characteristic

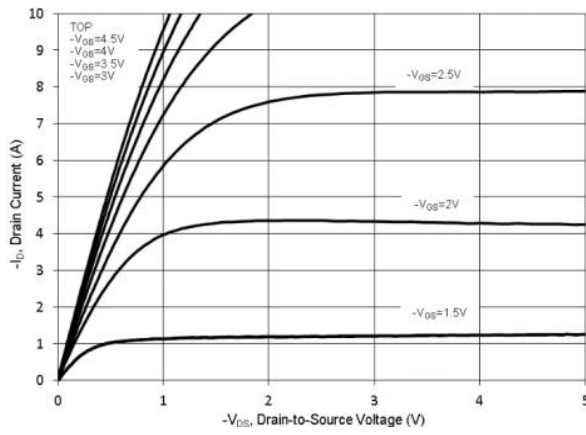

Fig. 2 Typical Transfer Characteristic

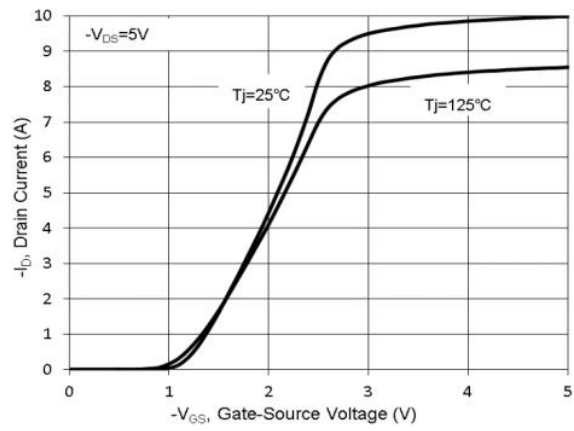

Fig. 3 on-Resistance vs. Gate Voltage

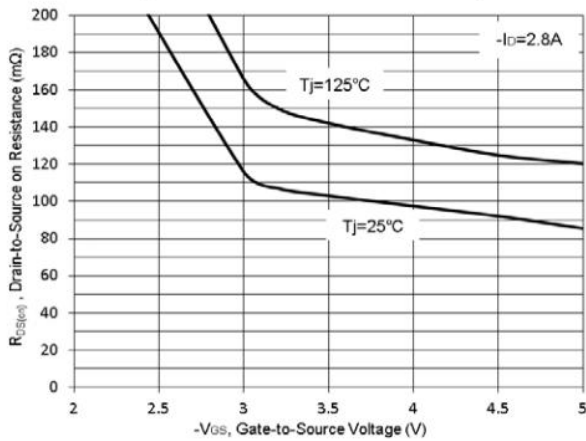

Fig. 4 on-Resistance vs.  $T_J$

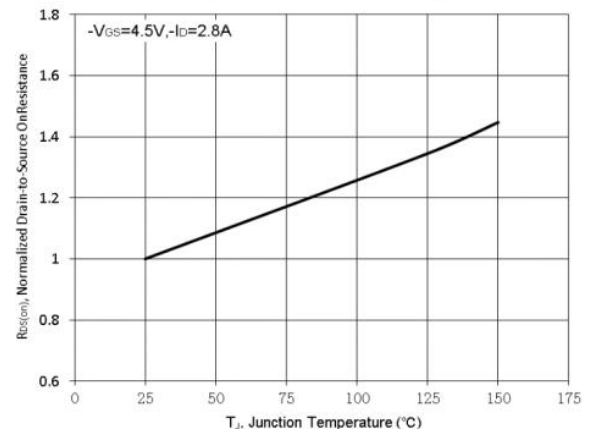

Fig. 5 Drain Current vs. on-Resistance

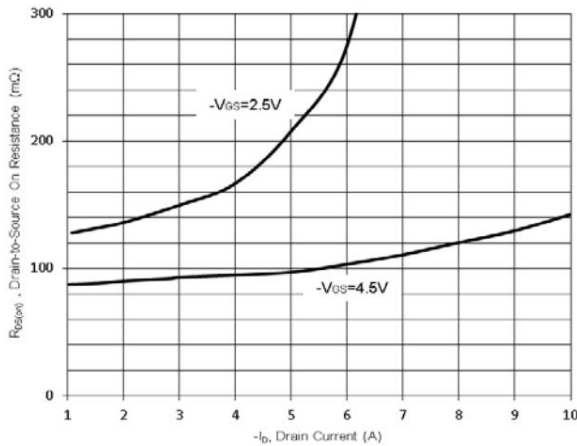
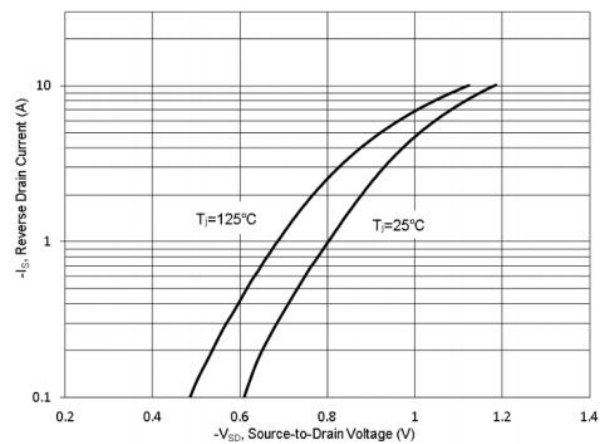

Fig. 6 Typical Forward Characteristic





Electrical Characteristics Curves

Fig. 7  $V_{(BR)DSS}$  vs. Junction Temperature

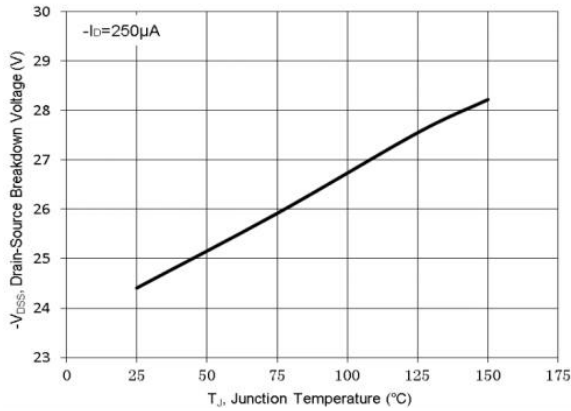

Fig. 8 Gate Threshold Variation vs.  $T_J$

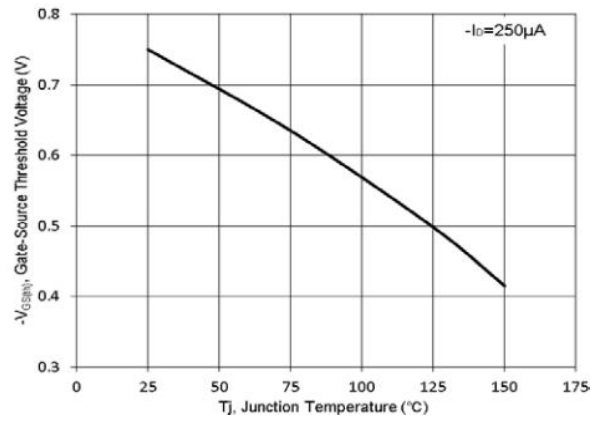

Fig. 9 Typical Junction Capacitance

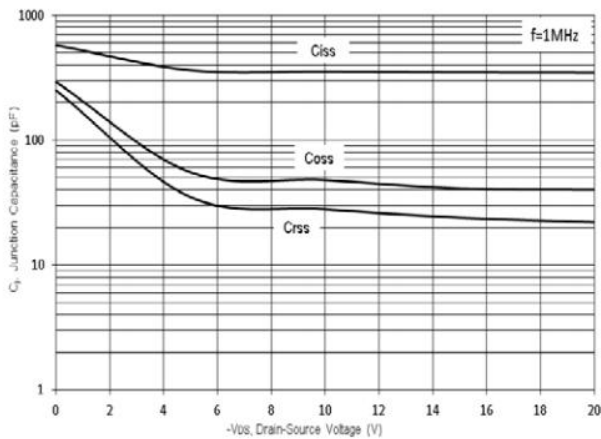

Fig. 10 Gate Charge

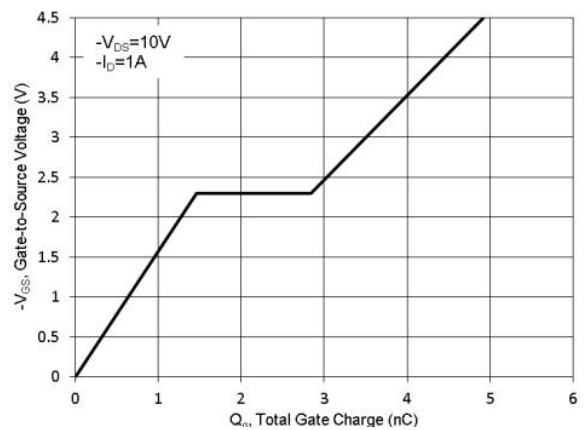

Fig. 11 Drain-Source Leakage Current

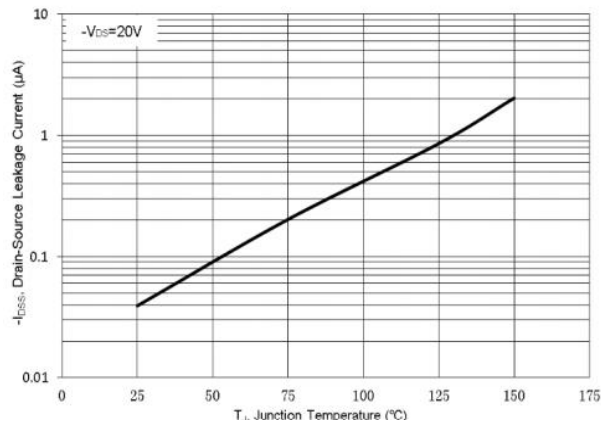
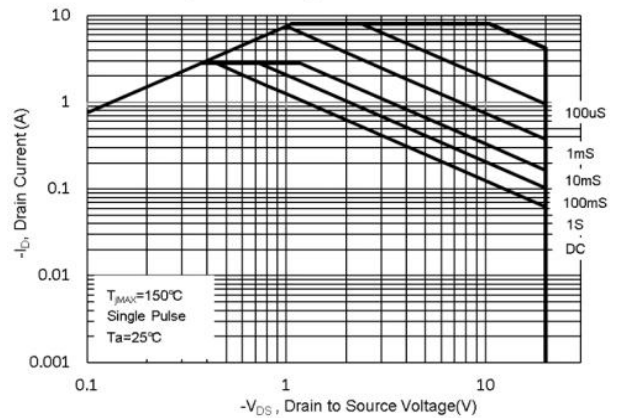

Fig. 12 Safe Operation Area





Electrical Characteristics Curves

Fig. 13 Transient Thermal Resistance

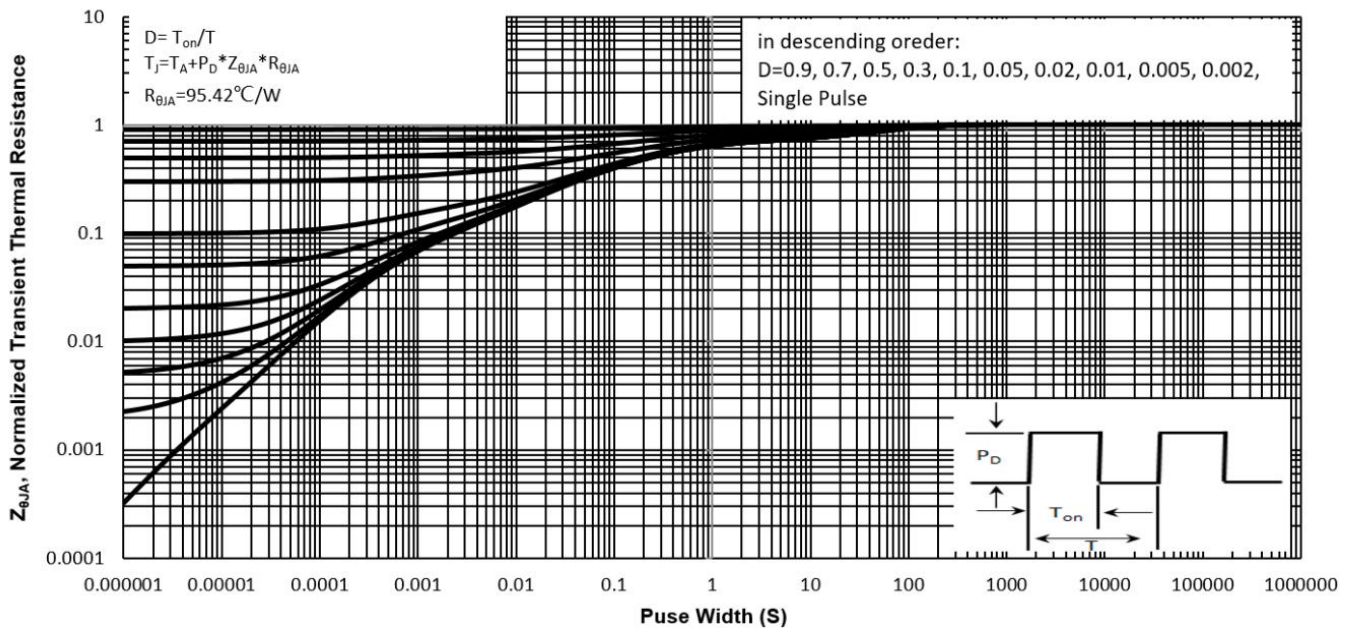



Test Circuits

Fig.1-1 Switching times test circuit

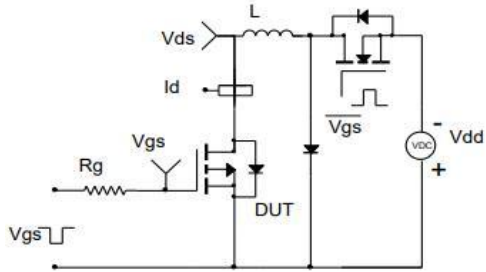

Fig.1-2 Switching Waveform

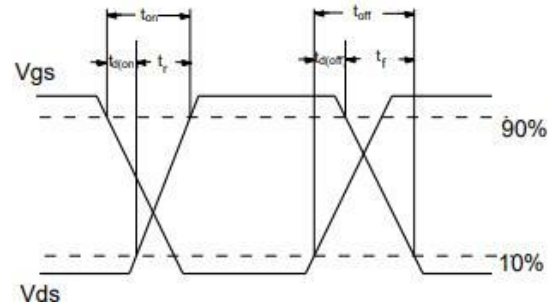

Fig.2-1 Gate charge test circuit

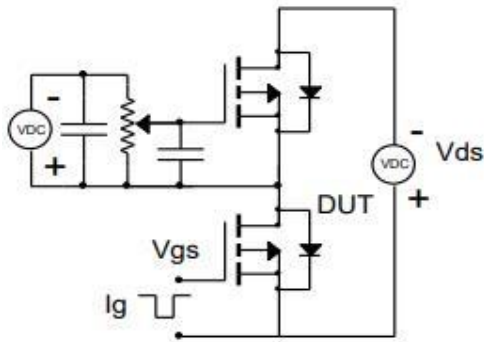

Fig.2-2 Gate charge waveform

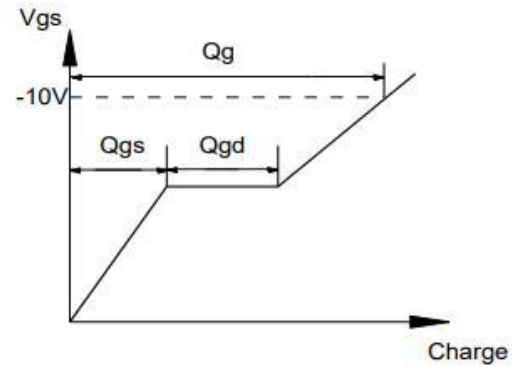

Fig.3-1 Avalanche test circuit

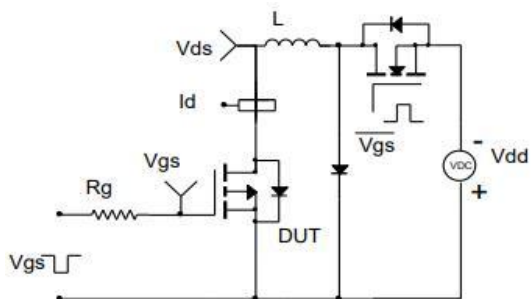
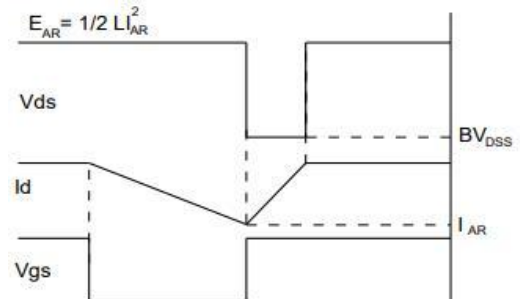

Fig.3-2 Avalanche waveform





**Soldering parameters**

Reflow Condition		Pb-Free assembly (see as bellow)
Pre Heat	-Temperature Min ( $T_{s(min)}$ )	+150°C
	-Temperature Max( $T_{s(max)}$ )	+200°C
	-Time (Min to Max) (ts)	60-180 secs.
Average ramp up rate (Liquid us Temp ( $T_L$ ) to peak)		3°C/sec. Max
$T_{s(max)}$ to $T_L$ - Ramp-up Rate		3°C/sec. Max
Reflow	-Temperature( $T_L$ )(Liquid us)	+217°C
	-Temperature( $t_L$ )	60-150 secs.
Peak Temp ( $T_P$ )		+260(+0/-5)°C
Time within 5°C of actual Peak Temp ( $t_p$ )		30 secs. Max
Ramp-down Rate		6°C/sec. Max
Time 25°C to Peak Temp ( $T_P$ )		8 min. Max
Do not exceed		+260°C

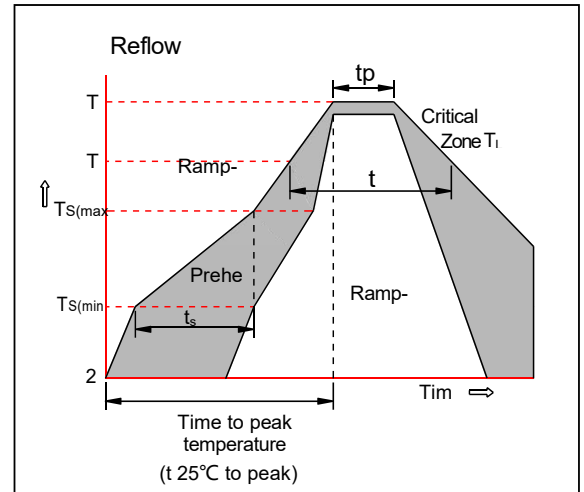

**Package Outline Dimensions (Units: mm)**

**SOT-23**

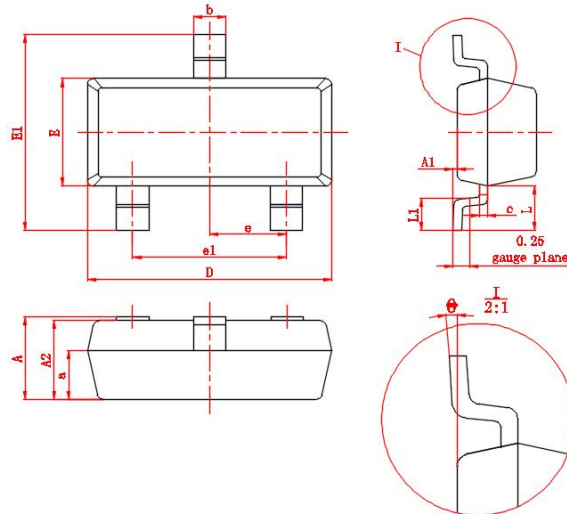

符号	尺寸		符号	尺寸		符号	尺寸	
	Min	Max		Min	Max		Min	Max
A	0.9	1.15	E	1.2	1.4	c	0.08	0.15
A1	0	0.1	E1	2.25	2.55	L	(0.55)	
A2	0.9	1.05	e	(0.95)		L1	0.3	0.5
a	(0.6)		e1	1.8	2.0	θ	0°	8°
D	2.8	3.0	b	0.3	0.5			



**Emboss Carrier Tape&Reel**

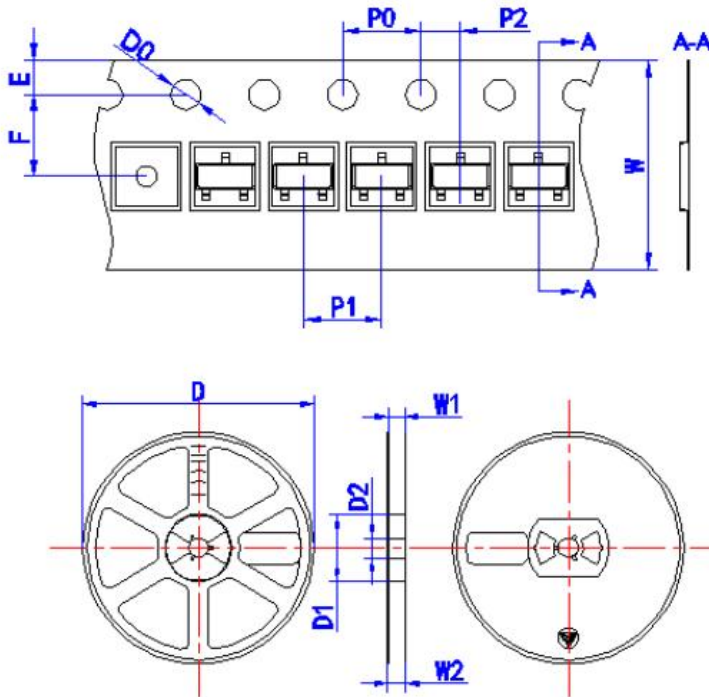

Symbol	Dimension in Millimeters
<b>Tape</b>	
D0	1.50+0.10/-0.00
E	1.75±0.10
F	3.50±0.10
P0	4.00±0.10
P1	4.00±0.10
P2	2.00±0.10
W	8.00+0.3/-0.1
<b>Reel</b>	
D	178.0±2.00
D1	54.40±1.00
D2	13.00±1.00
W1	9.50±1.00
W2	12.30±1.00