

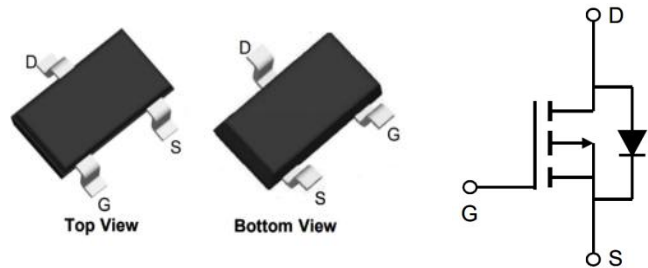

P-Channel Enhancement Mode MOSFET

Features

- Advanced trench cell design
- Low Thermal Resistance
- Low Gate Charge
- Fast Switching Speed



Application

- Load Switch for Portable Devices
- DC-DC converters
- Voltage controlled small signal switch

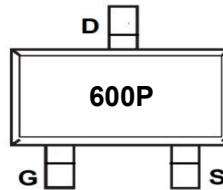

SOT-23
Marking: 600P

Halogen-Free & Lead-Free

Absolute Maximum Ratings (at $T_a = 25^\circ\text{C}$ unless otherwise specified)

Parameter	Symbol	Value	Unit
Drain-Source Voltage	V_{DS}	-30	V
Gate-Source Voltage	V_{GS}	± 20	V
Continuous Drain Current	I_D	-2.9	A
Peak Drain Current, Pulsed ¹⁾	I_{DM}	-10	A
Power Dissipation ²⁾ at $T_A=25^\circ\text{C}$	P_{tot}	0.9	W
Operating Junction	T_J	-55~150	$^\circ\text{C}$
Storage Temperature Range	T_{stg}	-55~150	$^\circ\text{C}$

Thermal Characteristics

Parameter	Symbol	Max.	Unit
Thermal Resistance from Junction to Ambient ²⁾	$R_{\theta JA}$	139	$^\circ\text{C/W}$
Thermal Resistance from Junction to Case ²⁾	$R_{\theta JC}$	70	$^\circ\text{C/W}$

Note:

1) Pulse width $\leq 300\mu\text{s}$, duty cycle $\leq 2\%$, limited by T_{jmax} .

2) Device mounted on FR-4 substrate PC board, 2ozcopper, with 1-inch square copper plate in still air.

**Characteristics at Ta = 25°C unless otherwise specified**

Parameter	Symbol	Min.	Typ.	Max.	Unit
STATIC PARAMETERS					
Drain-Source Breakdown Voltage at $I_D = -250 \mu\text{A}$	BV_{DSS}	-30			V
Drain-Source Leakage Current at $V_{DS} = -30 \text{ V}$	I_{DSS}			-1	μA
Gate Leakage Current at $V_{GS} = \pm 20 \text{ V}$	I_{GSS}			± 100	nA
Gate-Source Threshold Voltage at $V_{DS} = V_{GS}$, $I_D = -250 \mu\text{A}$	$V_{GS(th)}$	-1.2		-2.5	V
Drain-Source On-State Resistance at $V_{GS} = -10 \text{ V}$, $I_D = -3.8 \text{ A}$ at $V_{GS} = -4.5 \text{ V}$, $I_D = -3.0 \text{ A}$	$R_{DS(on)}$		60 105	75 132	m Ω
DYNAMIC PARAMETERS					
Forward Transconductance at $V_{DS} = -10 \text{ V}$, $I_D = -2.5 \text{ A}$	g_{fs}		6.2		S
Input Capacitance at $V_{GS} = 0 \text{ V}$, $V_{DS} = -15 \text{ V}$, $f = 1 \text{ MHz}$	C_{iss}		270		pF
Output Capacitance at $V_{GS} = 0 \text{ V}$, $V_{DS} = -15 \text{ V}$, $f = 1 \text{ MHz}$	C_{oss}		46		pF
Reverse Transfer Capacitance at $V_{GS} = 0 \text{ V}$, $V_{DS} = -15 \text{ V}$, $f = 1 \text{ MHz}$	C_{rss}		37		pF
Gate charge total at $V_{DS} = -15 \text{ V}$, $I_D = -2 \text{ A}$, $V_{GS} = -10 \text{ V}$	Q_g		7.2		nC
Gate to Source Charge at $V_{DS} = -15 \text{ V}$, $I_D = -2 \text{ A}$, $V_{GS} = -10 \text{ V}$	Q_{gs}		1.1		nC
Gate to Drain Charge at $V_{DS} = -15 \text{ V}$, $I_D = -2 \text{ A}$, $V_{GS} = -10 \text{ V}$	Q_{gd}		1.8		nC
Turn-On Delay Time at $V_{DS} = -15 \text{ V}$, $V_{GS} = -10\text{V}$, $I_D = -2 \text{ A}$, $R_{GEN} = 6 \Omega$	$t_{d(on)}$		15		nS
Turn-On Rise Time at $V_{DS} = -15 \text{ V}$, $V_{GS} = -10\text{V}$, $I_D = -2 \text{ A}$, $R_{GEN} = 6 \Omega$	t_r		36		nS
Turn-Off Delay Time at $V_{DS} = -15 \text{ V}$, $V_{GS} = -10\text{V}$, $I_D = -2 \text{ A}$, $R_{GEN} = 6 \Omega$	$t_{d(off)}$		43.5		nS
Turn-Off Fall Time at $V_{DS} = -15 \text{ V}$, $V_{GS} = -10\text{V}$, $I_D = -2 \text{ A}$, $R_{GEN} = 6 \Omega$	t_f		35		nS
Body-Diode PARAMETERS					
Drain-Source Diode Forward Voltage at $I_F = -2 \text{ A}$, $V_{GS} = 0 \text{ V}$	V_{SD}			-1.1	V
Body Diode Reverse Recovery Time at $I_F = -2 \text{ A}$, $di/dt = 100 \text{ A} / \mu\text{s}$	t_{rr}		11		nS
Body Diode Reverse Recovery Charge at $I_F = -2 \text{ A}$, $di/dt = 100 \text{ A} / \mu\text{s}$	Q_{rr}		3.3		nC



Electrical Characteristics Curves Output Characteristics

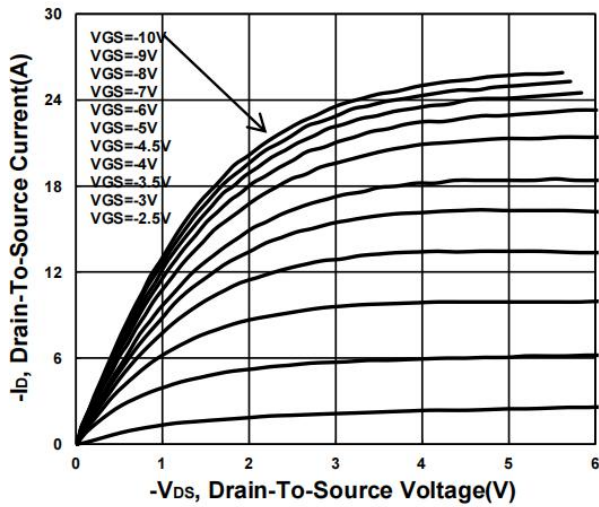

Transfer Characteristics

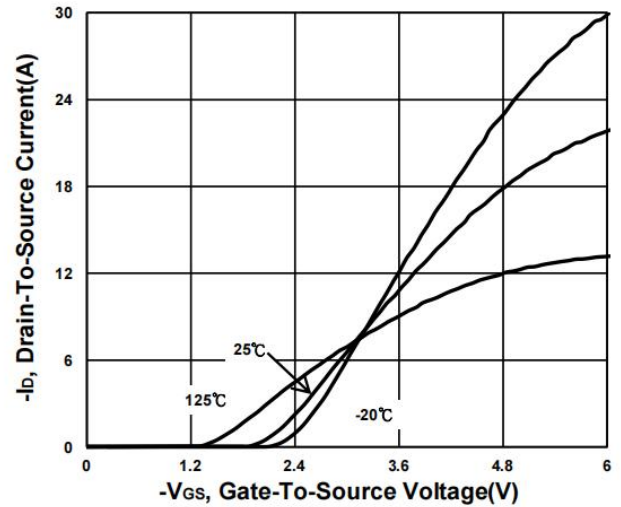

Gate charge Characteristics

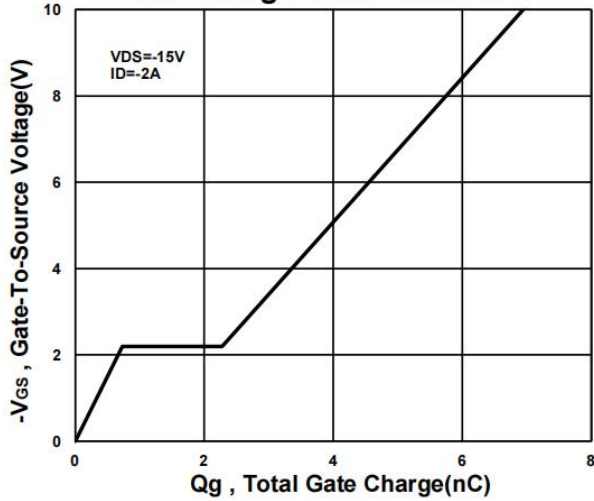

Capacitance Characteristic

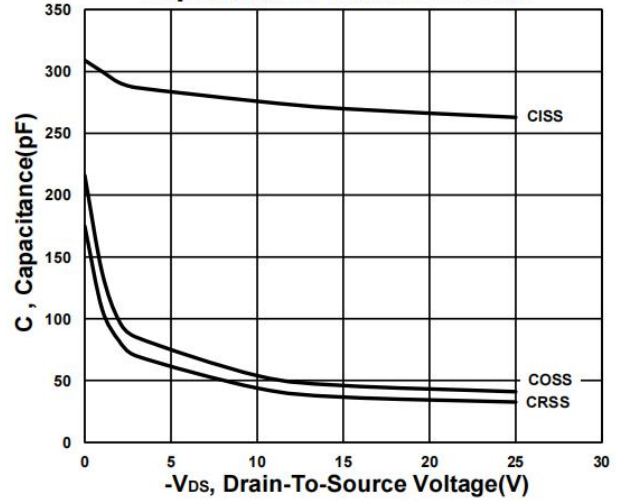

On-Resistance VS Gate-To-Source

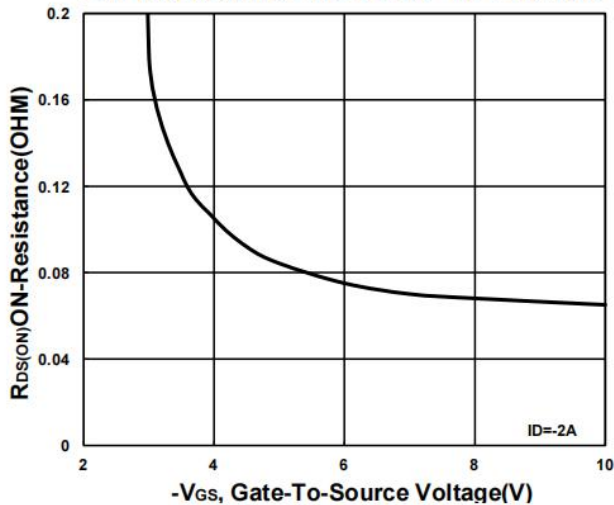

On-Resistance VS Drain Current

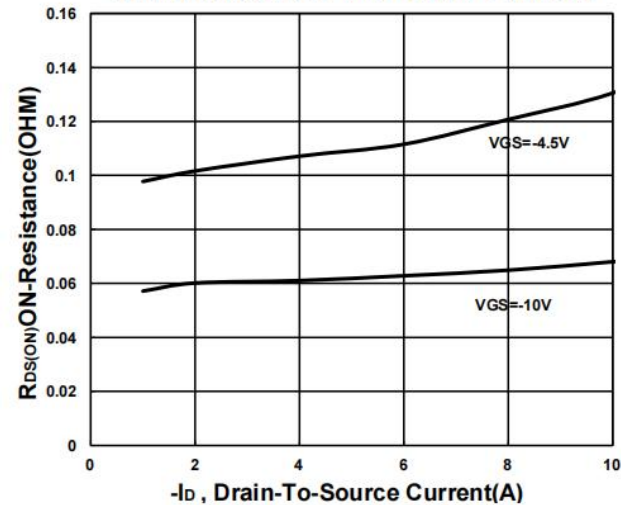



Electrical Characteristics Curves

On-Resistance VS Temperature

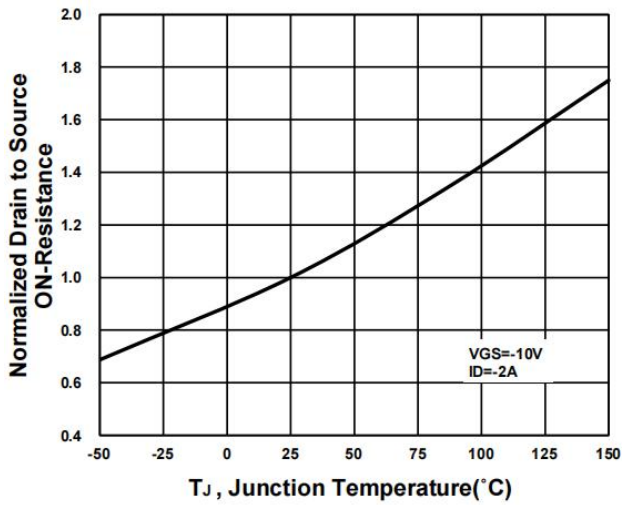

Source-Drain Diode Forward Voltage

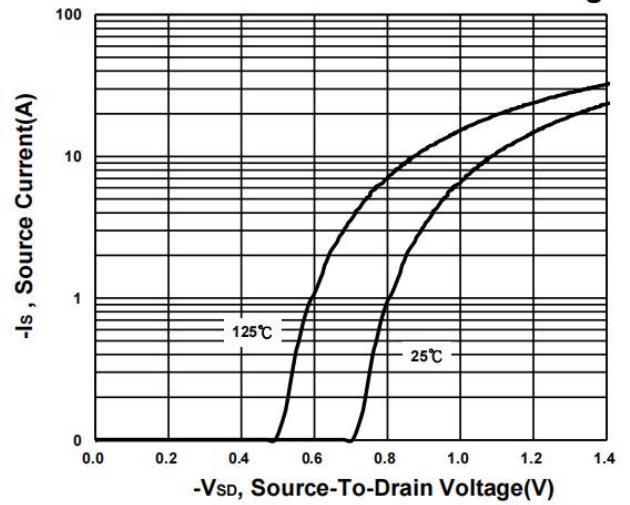

Safe Operating Area

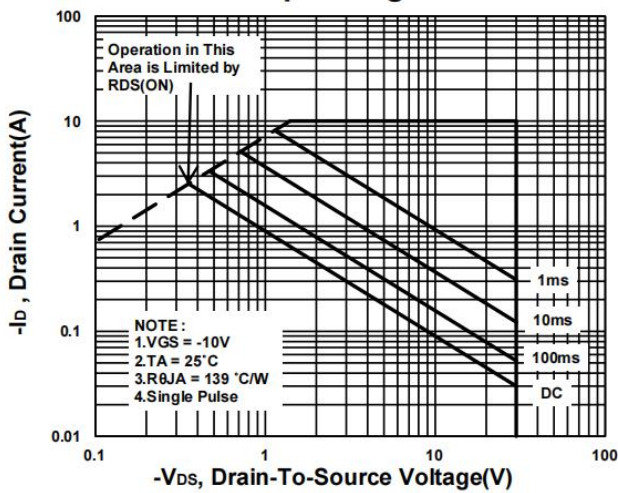

Single Pulse Maximum Power Dissipation

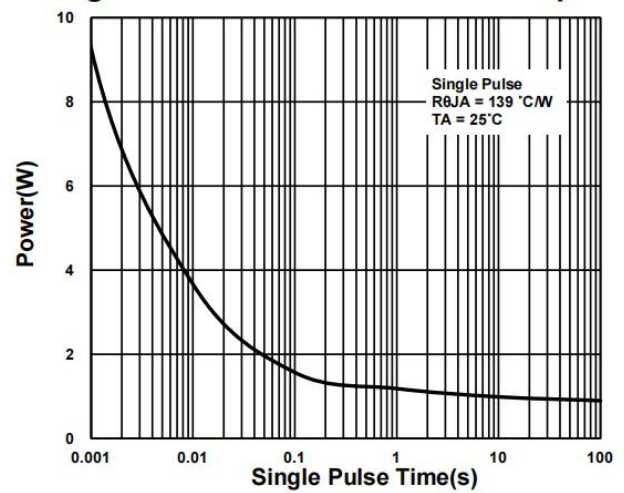

Transient Thermal Response Curve

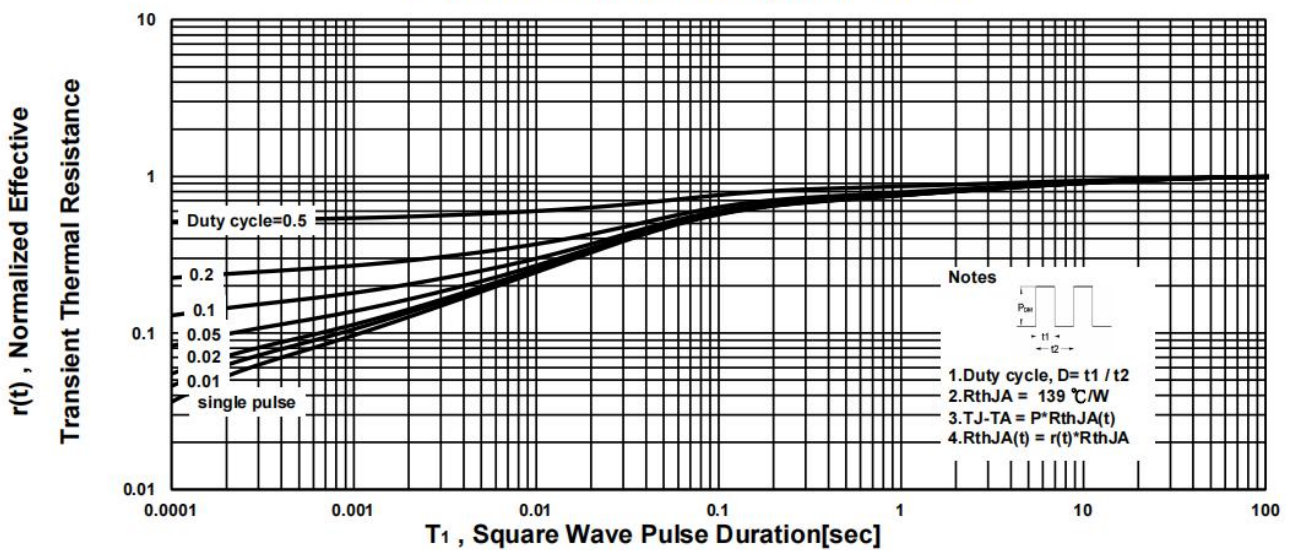



Test Circuits

Fig.1-1 Switching times test circuit

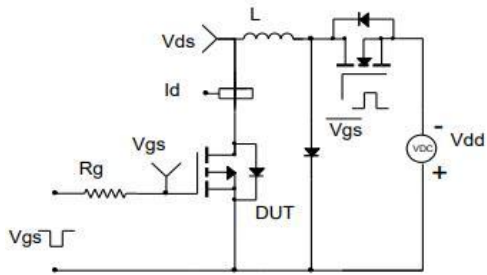

Fig.1-2 Switching Waveform

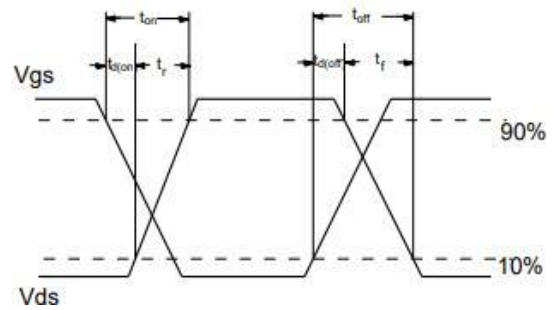

Fig.2-1 Gate charge test circuit

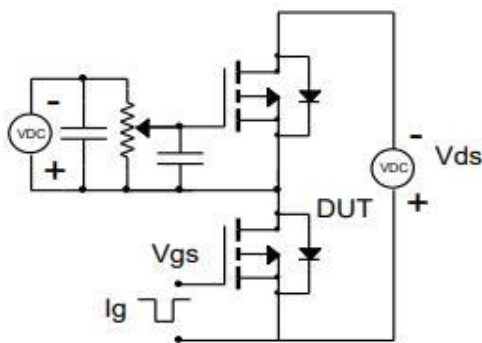

Fig.2-2 Gate charge waveform

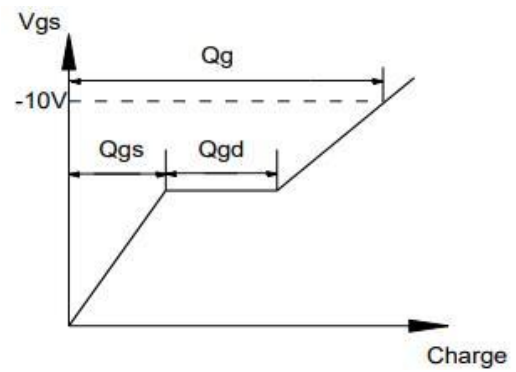

Fig.3-1 Avalanche test circuit

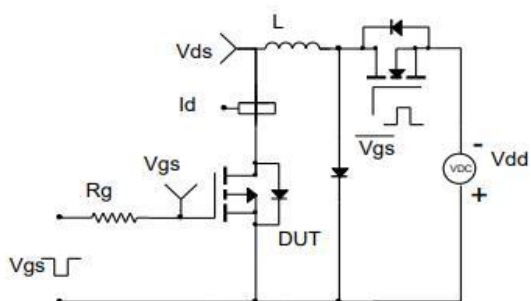
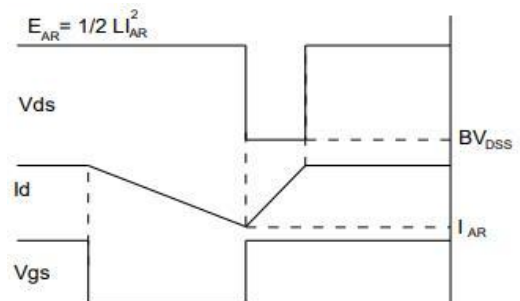

Fig.3-2 Avalanche waveform





Soldering parameters

Reflow Condition		Pb-Free assembly (see as below)
Pre Heat	-Temperature Min ($T_{s(min)}$)	+150°C
	-Temperature Max($T_{s(max)}$)	+200°C
	-Time (Min to Max) (ts)	60-180 secs.
Average ramp up rate (Liquid us Temp (T_L) to peak)		3°C/sec. Max
$T_{s(max)}$ to T_L - Ramp-up Rate		3°C/sec. Max
Reflow	-Temperature(T_L)(Liquid us)	+217°C
	-Temperature(t_L)	60-150 secs.
Peak Temp (T_P)		+260(+0/-5)°C
Time within 5°C of actual Peak Temp (t_p)		30 secs. Max
Ramp-down Rate		6°C/sec. Max
Time 25°C to Peak Temp (T_P)		8 min. Max
Do not exceed		+260°C

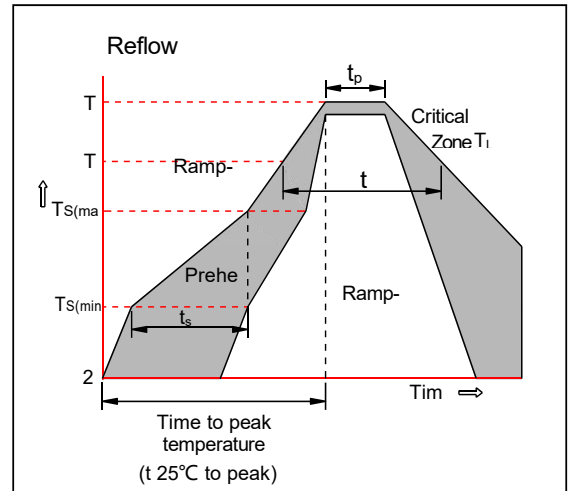

Package Outline Dimensions (Units: mm)

SOT-23

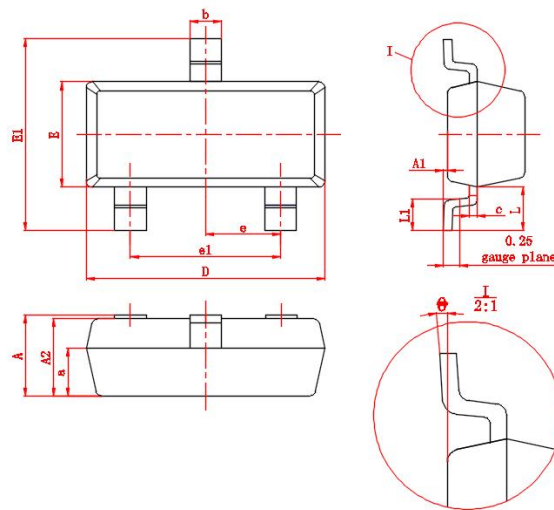

符号	尺寸		符号	尺寸		符号	尺寸	
	Min	Max		Min	Max		Min	Max
A	0.9	1.15	E	1.2	1.4	c	0.08	0.15
A1	0	0.1	E1	2.25	2.55	L	(0.55)	
A2	0.9	1.05	e	(0.95)		L1	0.3	0.5
a	(0.6)		e1	1.8	2.0	θ	0°	8°
D	2.8	3.0	b	0.3	0.5			